



2025 - 2028

# Equipment Rules of Sailing

sport / nature / technology



---

**THE  
EQUIPMENT RULES  
OF  
SAILING**

**for 2025-2028**

**World Sailing**

World Sailing has an ambitious wide ranging sustainability strategy safeguarding the future of the sport whilst protecting the waters of the world. This was ratified in May 2018. Sustainability Agenda 2030 can be accessed here: <https://www.sailing.org/about/Sustainability>

**Contact Details for the World Sailing Executive Office:**

World Sailing, Office 401 4<sup>th</sup> Floor  
3 Shortlands  
London W6 8DA  
UK

**Email** [office@sailing.org](mailto:office@sailing.org)

**[www.sailing.org](http://www.sailing.org)**

Published by World Sailing (UK) Ltd., London, UK  
© World Sailing Ltd.

# CONTENTS

---

|  |    |
|--|----|
| Introduction .....   | 4  |
| <b>Part 1 – Use of Equipment</b>                                 |    |
| Section A – During an Event .....                                | 6  |
| Section B – While Racing .....                                   | 7  |
| <b>Part 2 – Definitions</b>                                      |    |
| Section C – General Definitions .....                            | 8  |
| Section D – Hull Definitions .....                               | 15 |
| Section E – Hull Appendage Definitions .....                     | 17 |
| Section F – Rig Definitions .....                                | 19 |
| Section G – Sail Definitions .....                               | 35 |
| Subsection A – Trilateral Sails .....                            | 35 |
| Subsection B – Additions for Other Sails .....                   | 50 |
| <b>Part 3 – Rules Governing Equipment Control and Inspection</b> |    |
| Section H – Equipment Control and Inspection .....               | 53 |
| <b>Appendix 1</b>  |    |
| Racing Rules that govern the use of equipment.....               | 57 |
| <b>Appendix 2</b>  |    |
| Abbreviations for primary sail dimensions .....                  | 58 |
| Index of Defined Terms .....                                     | 59 |



# INTRODUCTION

---

The *Equipment Rules of Sailing* includes and references:

- Rules for use of equipment.
- Definitions of equipment, measurement points and measurements for use in **class rules** and other rules and regulations.
- Rules governing **certification control** and **equipment inspection**.

## Applicability

The ERS are invoked by:

- (a) **Class Rules**.
- (b) A notice of race and sailing instructions.
- (c) Prescriptions of an MNA for races under its jurisdiction.
- (d) World Sailing Regulations,
- (e) World Sailing Racing Rules of Sailing, or
- (f) Other documents that govern an event.

ERS Parts A, B, C and H apply at all times, except as permitted by the rules themselves.

ERS definitions marked with an asterisk (\*) are optional for Classes approved by WS prior to 1997.

## Terminology

A term used in its defined sense is printed in “**bold**” if defined in the ERS and in “*italic*” if defined in the RRS. The use of an ERS term in its defined sense may also be used in other forms of the word and shall refer to the original defined term. Other words and terms are used in the sense ordinarily understood in nautical or general use in English.

## Abbreviations

|     |   |
|-----|---|
| MNA | World Sailing Member National Authority                     |
| ICA | International Class Association or recognised Rating System |
| NCA | National Class Association                                  |
| ERS | The Equipment Rules of Sailing                              |
| RRS | The Racing Rules of Sailing                                 |
| TC  | An Event Technical Committee as defined in Racing Rule 92.  |
| ER  | Equipment Regulations                                       |

## Revision

The Equipment Rules are revised and published every four years by World Sailing, the international authority for the sport. This edition becomes effective on 1 January 2025 except that for an event beginning in 2024 the date may be postponed by the Notice of Race and Sailing Instructions. Changes to the Equipment Rules are permitted under World Sailing Regulations 29.1.1 and 29.1.2. No changes are contemplated before 2028, but any changes determined to be urgent before then will be announced through National Authorities and posted on the World Sailing website ([sailing.org](http://sailing.org)).

## INTRODUCTION

---

### Changes

The ERS may only be changed as follows:

- (a) Prescriptions of an MNA may change a rule in ERS Part 1, for races under its jurisdiction.
- (b) **Class rules** may change ERS rules as permitted by rule A.1.

These restrictions do not apply if rules are changed to develop or test proposed rules in local races. The MNA may prescribe that its approval is required for such changes.

Marginal markings indicate substantial changes to the 2021 – 2024 edition.

# PART 1 – USE OF EQUIPMENT

---

In addition to the rules in Part 1, **class rules** and the *Racing Rules of Sailing* contain rules governing the use of equipment. Appendix 1 provides a list of those racing rules.

## Section A – During an Event

### A.1 CLASS RULES

**Class rules** may change rules B.1, B.2 and B.3.

### A.2 CERTIFICATE

#### A.2.1 Having a Certificate

The **boat** shall have a valid **certificate** as required by its **class rules** or the **certification authority**.

#### A.2.2 Compliance with a Certificate

The **boat** shall comply with its **certificate**.

See also RRS 78 Compliance with Class Rules; Certificates.



## Section B – While Racing

### B.1 POSITION OF EQUIPMENT

#### B.1.1 Mast Upper Limit Mark

(a) TRILATERAL MAINSAIL

The **mainsail** shall be set so that no visible part of it shall be higher than a line projected 90° to the **mast spar** at the **upper point**.

(b) QUADRILATERAL MAINSAIL

The **throat point**, projected at 90° the **mast spar**, shall not be set higher than the **upper point**.

#### B.1.2 Mast Lower Limit Mark

When a **sail** is set on a **main boom**, **foremast boom** or **mizzen boom**, the extension of the upper edge of the **spar** shall intersect the **mast spar** above the **mast lower limit mark**, with the **boom spar** on the **mast spar** centreplane and at 90° to the **mast spar**.

#### B.1.3 Boom Outer Limit Mark

The **leech** of any **sail** set on a **boom**, extended as necessary, shall intersect the upper edge of the **boom spar** forward of the **boom outer point**.

#### B.1.4 Bowsprit Outer Limit Mark

The **tack** of any **headsail** set on a **bowsprit** shall be **connected** aft of the **bowsprit outer point**.

#### B.1.5 Bowsprit Inner Limit Mark

The **bowsprit inner point** shall not be outboard of the **hull** when the **bowsprit** is set.

### B.2 HEADSAIL BOOMS

The fore end of a **headsail boom** shall be approximately on the **boat** centerplane.

### B.3 SPINNAKER STAYSAILS AND MIZZEN STAYSAILS

The **tack** of a spinnaker staysail or **mizzen** staysail shall be inboard the **sheerline**

## PART 2 – DEFINITIONS

---

### Section C – General Definitions

#### C.1 CLASS

##### C.1.1 Class Authority

The body that governs the class as specified in the **class rules**.

#### C.2 RULES

##### C.2.1 Class Rules

The rules that specify:

the **boat** and its use, **certification** and administration.

the **crew**.

**personal equipment** and its use, **certification** and administration.

**portable equipment** and its use, **certification** and administration.

any other equipment and its use, **certification** and administration.

changes to the *Racing Rules of Sailing* as permitted by RRS 86.1(c).

The term includes rules of handicap and rating systems.

##### C.2.2 Closed Class Rules

**Class rules** where anything not specifically permitted by the **class rules** is prohibited.

##### C.2.3 Open Class Rules

**Class rules** where anything not specifically prohibited by the **class rules** is permitted.

##### C.2.4 Class Rules Authority

The body that provides final approval of the **class rules**, **class rule** changes and **class rule** interpretations.

#### C.3 CERTIFICATION

##### C.3.1 Certification Authority

World Sailing, the MNA in the country where the **certification** shall take place, or their delegates.

##### C.3.2 Certify/Certification

To issue a **certificate**, or apply a **certification mark** after successful **certification control**.

## PART 2 DEFINITIONS

---

### C.3.3 Certificate

Documentary proof of successful **certification control** as required by the **class rules** or a **certification authority**.

For the **hull**: issued by World Sailing, the MNA of the owner, or their delegates.

For other items: issued by the **certification authority**.

The term includes handicap and rating certificates.

### C.3.4 Certification Mark

Proof of successful **certification control** of a part requiring **certification** applied as required by the **class rules** or a **certification authority**.

### C.3.5 Licensed Manufacturer's Mark

The mark required by class rules and used to indicate that equipment is produced by a licensed manufacturer.

## C.4 CERTIFICATION CONTROL AND EQUIPMENT INSPECTION

See also H.1 and H.2.

### C.4.1 Fundamental Measurement

The methods used as the primary means to establish the physical properties of equipment.

### C.4.2 Certification Control

The methods used as means of equipment control required by **class rules**, or a **certification authority**, for **certification**.

### C.4.3 Event Equipment Inspection

Control carried out by the TC at an event as required by the notice of race, the sailing instructions and/or the ER, which may include **fundamental measurement**.

### C.4.4 Certification Measurer

A person appointed or recognised, by the MNA of the country where the control takes place, to carry out **certification control** and when the **class rules** permit, **certification**. An MNA may have delegated this responsibility.

### C.4.5 In-House Certification Measurer

A person appointed to carry out **certification control** in accordance with the World Sailing In-House Certification Programme.

### C.4.6 Equipment Inspector

A person appointed by a TC to carry out **equipment inspection**.

### C.4.7 Limit Mark

A clearly visible permanent mark of a single colour, contrasting to the part(s) on which it is placed, indicating a measurement point.

## PART 2 DEFINITIONS

---

### C.4.8 Event Limitation Mark

A mark permanently attached by a TC on equipment whose replacement at the event is controlled by the **class rules**.

### C.4.9 Equipment Regulations (ER)

*Rules* published by the TC that govern the **event equipment inspection**.

## C.5 PERSONAL DEFINITIONS

### C.5.1 Crew

A competitor, or team of competitors, that operates a **boat**.

### C.5.2 Helmsperson

A **crew** member who helms a **boat**.

### C.5.3 Personal Equipment

All personal effects carried or worn and items worn on board to keep warm and/or dry, and/or to protect the body, **personal flotation device**, **crew harness** and hiking aids or safety equipment worn to keep the person aboard or afloat.

### C.5.4 Personal Flotation Device

**Personal equipment** as required by the *rules* to assist the user to float in water. **Class rules** or the World Sailing Offshore Special Regulations shall prescribe the required standards, if any.

### C.5.5 Crew Harness

**Personal equipment** worn to assist the **crew** to use a **trapeze** or to hike or to stay **connected** to a **windsurf sail**, a **kite** or a **wingfoil**. **Class rules** shall prescribe the required standards, if any.

### C.5.6 Impact Vest

**Personal equipment** designed to provide protection against impacts to the torso. **Class rules** shall prescribe the required standards, if any.

## C.6 BOAT DEFINITIONS

### C.6.1 Boat

The equipment used by the **crew** to take part in a race.

It includes:

**hull(s)**

structure(s) connecting **hulls**

**hull appendage(s)**

**ballast**

**rig**

**sail(s)**

**fittings**

boat **corrector weights** and

all other items of equipment used

## PART 2 DEFINITIONS

---

but excludes  
consumables  
**personal equipment** and  
**portable equipment.**

### C.6.2 Boat Types

- (a) MONOHULL  
A **boat** with one **hull**.
- (b) MULTIHULL  
A **boat** with more than one **hull**.
- (c) WINDSURFER  
A **boat**.
- (d) KITE-BOARD  
A **boat**.
- (e) WINGFOIL  
A **boat**.

### C.6.3 Boat Control Definitions

- (a) MAJOR AXES  
The three major axes of the **boat** at 90° to each other – vertical, longitudinal and transverse – shall be related to the baseline and the **hull centreplane**.  
See H.3.
- (b) MEASUREMENT TRIM  
Trim achieved when two points on the **hull(s)** are at set distances perpendicular to a plane. The plane, the points and distances to be specified in **class rules**.
- (c) FLOTATION TRIM  
Trim achieved with the **boat** floating in accordance with H.7.1 – Conditions for Weight and Flotation Measurement.
- (d) WATERLINE  
The line(s) formed by the intersection of the outside of the **hull(s)** and the water surface when the **boat** is floating in **measurement trim**.
- (e) WATERPLANE  
The plane passing through the **waterline**.
- (f) BALLAST  
Weight **installed** to influence the stability, flotation, trim or total weight of the **boat**.  
**Ballast** types:
  - (i) INTERNAL BALLAST  
**Ballast** positioned inside a **hull**.
  - (ii) EXTERNAL BALLAST  
**Ballast** positioned outside a **hull**.
  - (iii) MOVEABLE BALLAST

## PART 2 DEFINITIONS

---

**Internal ballast** or **external ballast** that may be moved.

(iv) VARIABLE BALLAST

Water **ballast** the amount of which may be varied and which may also be moved.

(v) CORRECTOR WEIGHT

Weight **installed** in accordance with the **class rules** to correct deficiency in weight and/or its distribution.

(g) CONNECT

To bring together or into contact so that a real link is established by which one item affects the function of the other; therefore includes “attached to” and “sheeted to” the corner of the **sail**.

### C.6.4 Boat Dimensions

(a) BOAT LENGTH

The longitudinal distance between the aftermost point and the foremost point of the **boat**, excluding **sails**, with **spars** set as appropriate.

See H.3.4.

(b) BOAT BEAM

The transverse distance between the outermost points of the **boat**.

(c) WATERLINE LENGTH

The longitudinal distance between the aftermost point and the foremost point of the **waterline**.

(d) WATERLINE BEAM

The transverse distance between the outermost points of the **waterline**.

(e) DRAFT

The vertical distance between the **waterplane** and the lowest point of the **boat**.

(f) MINIMUM DRAFT

The **draft** with all **hull appendages** in their highest position.

(g) MAXIMUM DRAFT

The **draft** with all **hull appendages** in their lowest position.

(h) BOAT WEIGHT

The weight of the **boat** excluding **sail(s)** and **variable ballast**.

(i) LIST ANGLE

The maximum angle of heel of the **boat**, measured relative to the **boat** floating upright, in the condition for weight and flotation measurement with **moveable ballast** moved fully to port or starboard.

(j) HULL APPENDAGE DEPTH

The maximum vertical distance between the **hull** shell or a measurement point as specified in the **class rules** and the lowest point of a **hull appendage** in its lowest position.

## PART 2 DEFINITIONS

---

### C.6.5 Boat Age

(a) SERIES DATE

The date on which the first **boat** of the design or the production series was first launched, whichever is earlier. Series Date does not change if the **boat** is modified.

(b) AGE DATE

The date on which the **boat** was first launched, or the date on which the **boat** was re-launched following any **hull shell modification**, excluding the transom, whichever is the later.

### C.6.6 Portable Equipment

Removable equipment permitted by **class rules** excluding:

the **boat**,  
**personal equipment**, and  
consumables.

Typical examples of portable equipment would include anchor and chain, mooring or towing lines, paddles, bailers, spare fittings and ropes.

## C.7 BOAT MODIFICATIONS, MAINTENANCE AND REPAIR

### C.7.1 Terms

(a) INSTALLATION

The **bonding** or **fastening** of a **fitting** directly to the **boat**. This may include the drilling of holes, when and where permitted, through which fasteners are attached.

(b) FITTING

An item, including any associated **fitting**, that is not part of the **boat** structure but is bonded or fastened to the **hull, hull appendages or rig**.

(c) FASTENING

To fix in place with bolts, screws, rivets or other suitable means.

(d) BONDING

To fix in place with glues, resins, sealants or other similar chemical agents.

(e) COATING

Application of an additional permanent layer or layers of a substance to a surface. This may require prior preparation of the surface which may involve **sanding**, etching, blasting, but not **fairing**.

(f) SANDING

Removal of the outermost surface through use of an abrasive material with or without a **lubricating** agent, which does not alter the shape but may remove localised irregularities or textures in the surface.

(g) CLEANING

## PART 2 DEFINITIONS

---

The application and subsequent removal of detergents or similar agents, the purpose of which is to remove residue on the surface.

(h) **POLISHING**

The application of cutting compounds with or without a **lubricating** agent, in order to reduce surface roughness.

(i) **FAIRING**

The addition and/or removal of material to alter the shape.

(j) **LUBRICATING**

The application of non-permanent friction reducing compound.

(k) **SEALED IN POSITION**

Securing or locking something in place to prevent movement. The use of seals, stickers, or other marking devices to indicate if something has been moved.

(l) **SEALED CLOSED**

Locking something to prevent access. The use of seals, stickers, or other marking devices to indicate if something has been moved.

### **C.7.2 Modification**

Work resulting in a change to the original condition.

### **C.7.3 Maintenance**

Work required to retain the original condition, compensating for normal wear and tear in order to achieve its maximum useful life. This includes preventive **maintenance** and may include **coating, sanding, lubricating, polishing** and **cleaning**, but shall exclude **fairing** and **bonding**.

### **C.7.4 Repair**

Corrective action, following unintended damage, required to restore the original condition and shape. This may include **coating, sanding, fairing, polishing** and **bonding**.



## Section D – Hull Definitions

### D.1 HULL TERMS

#### D.1.1 Hull

The hull shell including any transom, the deck including any superstructure, the internal structure including any cockpit, wings or racks, the **fittings** installed on these parts and any **corrector weights**.

#### D.1.2 Sheerline \*

The line formed by the intersection of the top of the deck and the outside of the hull shell, each extended as necessary.

#### D.1.3 Sheer

The projection of the **sheerline** on the centreplane.

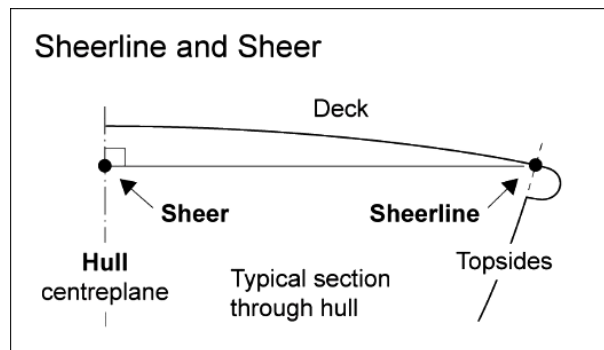

### D.2 HULL MEASUREMENT POINTS

#### D.2.1 Hull Datum Point

A point on the **hull** specified in the **class rules** from which **hull** measurements can be taken.

### D.3 HULL DIMENSIONS

#### D.3.1 Hull Length

The longitudinal distance between the aftermost point and the foremost point on the **hull(s)**, excluding **fittings**.

See H.3.4.

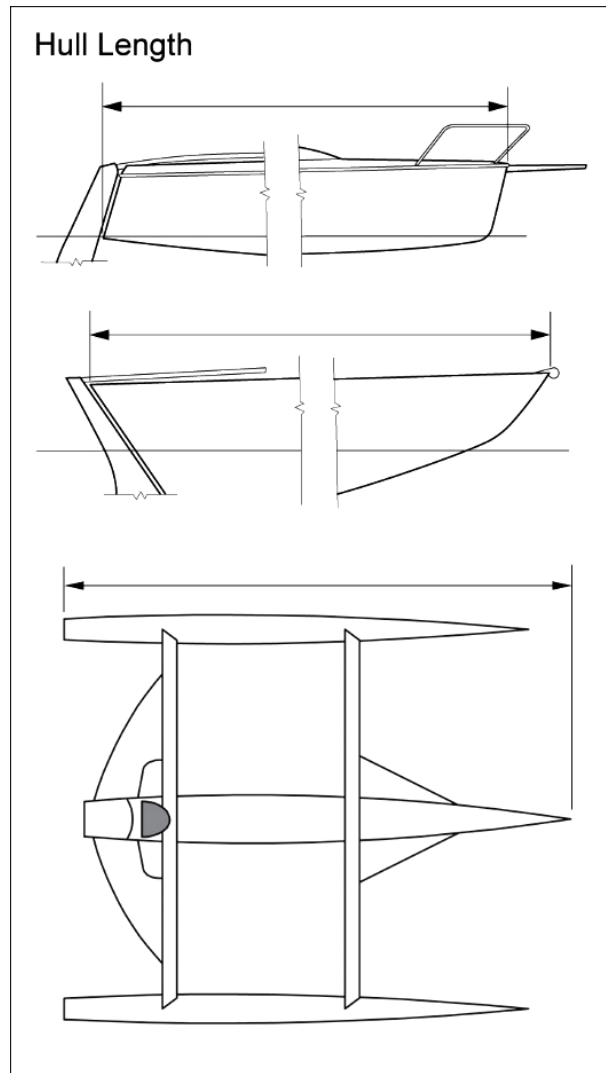

### D.3.2 Hull Beam \*

The maximum transverse distance between the outermost points of the **hull(s)** excluding **fittings**.

### D.3.3 Hull Depth

The vertical distance between the **waterplane** and the lowest point of the **hull**.

## D.4 WEIGHT

### D.4.1 Hull Weight

The weight of the **hull**.

## Section E – Hull Appendage Definitions

### E.1 HULL APPENDAGE TERMS

#### E.1.1 Hull Appendage

Any item of equipment – including the items listed in E.1.2– which is:  
wholly or partly below the **sheerline** or its extension when fixed or when fully exposed if retractable,  
attached to the hull shell or another **hull appendage**, and  
used to affect: stability, leeway, steerage, directional stability, motion damping, trim, displaced volume,

Any of the following shall be included in the **hull appendage**:

**corrector weights**,  
integral **ballast**, and  
associated **fittings**.

#### E.1.2 Hull Appendage Types

(a) KEEL

A fixed **hull appendage**, attached approximately on the **hull** centreplane, primarily used to affect stability and leeway.

(b) BILGE KEEL

A fixed **hull appendage**, attached off the **hull** centreplane, primarily used to affect stability and leeway.

(c) CANTING KEEL

A movable **hull appendage** primarily used to affect stability, attached approximately on the **hull** centreplane and rotating around a single longitudinal axis.

(d) FIN

A fixed **hull appendage** primarily used to affect leeway or directional control.

(e) BULB

A **hull appendage** containing **ballast** at the bottom of another **hull appendage**, primarily used to affect stability.

(f) SKEG

A **fin** attached immediately in front of a **rudder**.

(g) CENTREBOARD

A retractable **hull appendage**, attached approximately on the **hull** centreplane and rotating about a single transverse axis which may move in relation to the **hull**, primarily used to affect leeway.

(h) DAGGERBOARD

A retractable **hull appendage**, attached approximately on the **hull** centreplane and not rotating, primarily used to affect leeway.

(i) BILGEBOARD

## PART 2 DEFINITIONS

---

A retractable **hull appendage**, attached off the **hull** centreplane, primarily used to affect leeway.

(j) **RUDDER**

A movable **hull appendage** primarily used to affect steerage.

(k) **TRIM TAB**

When a **rudder(s)** is used, a movable **hull appendage**, attached at the aft, or fore edge of another **hull appendage**.

(l) **WINGLET**

A **hull appendage** attached to a **keel, bilge keel** or **bulb**, primarily used to affect leeway and/or lift.

(m) **HYDROFOIL**

A **hull appendage** primarily used to affect leeway and/or produce vertical lift, which may incorporate any or all of the following:

Fuselage,

Foil mast,

Elevator,

Front wing,

Rear wing.

## E.2 HULL APPENDAGE MEASUREMENT DEFINITIONS

### E.2.1 Hull Appendage Weight

The weight of the **hull appendage** excluding any associated **fittings**.

### E.2.2 Hull Appendage Assembly Weight

The weight of the **hull appendage** including any associated **fittings** and other parts prescribed in **class rules**.

### E.2.3 Wingspan

The maximum transverse distance between the outermost points of any **winglets** or a **hydrofoil**.

## Section F – Rig Definitions

### F.1 GENERAL RIG TERMS

#### F.1.1 Rig

The **spars, spreaders, rigging, fittings** and any **corrector weights**.

#### F.1.2 Rig Configurations

(a) UNA RIG

A single-masted **rig** with a **mainsail** only.

(b) SLOOP RIG

A single-masted **rig** with a **mainsail** and one **headsail**.

(c) CUTTER RIG

A single-masted **rig** with more than one **headsail**.

(d) KETCH RIG

A two-masted **rig** with the the **mainmast** taller than the the **mizzenmast** set forward of the rudder stock.

(e) YAWL RIG

A two-masted **rig** with the **mainmast** taller than the the **mizzenmast** set aft of the rudder stock.

(f) SCHOONER RIG

A two-masted **rig** with the **foremast** shorter than, or the same height as, the **mainmast**.

#### F.1.3 Spar(s)

The main structural part(s) of the **rig** to which **sails** are **connected**. It includes its **fittings** and any **corrector weights**.

#### F.1.4 Spar Types

(a) MAST

A **spar** on which the **head** or **throat** of a **sail**, or a **yard**, is **connected**. Includes its **standing rigging, running rigging**, and **spreader**s, but not **running rigging** and **fittings** that are not essential to the function of the mast as part of the **rig**.

**Mast** Types:

(i) MAINMAST

(a) The only **mast** in a **una rig, sloop rig** or **cutter rig**.

(b) The fore **mast** in a **ketch rig** or **yawl rig**.

(c) The aft **mast** in a **schooner rig**.

(ii) FOREMAST

The fore **mast** in a **schooner rig**.

(iii) MIZZENMAST

The aft **mast** in a **ketch rig** or **yawl rig**.

## PART 2 DEFINITIONS

---

### (b) BOOM

A **spar** attached at one end to a **mast spar** or a **hull** and on which the **clew** of a **sail** is **connected** and on which the **tack** and/or **foot** of the **sail** may be **connected**. Includes its **rigging**, but not **running rigging**, **running rigging** blocks and/or any **vang** arrangement.

**Boom** Types:

#### (i) FOREMAST SAIL BOOM

A **boom** attached to a **foremast spar** to **connect** a **foremast sail**.

#### (ii) HEADSAIL BOOM

A **boom** attached to a **hull** to **connect** a **headsail clew**.

#### (iii) MAIN BOOM

A **boom** attached to a **mainmast spar** to **connect** a **mainsail**.

#### (iv) MIZZEN BOOM

A **boom** attached to a **mizzenmast spar** to **connect** a **mizzen**.

#### (v) WISHBONE BOOM

A double **boom** attached to a **mast spar** to **connect** a **sail** and which has one **spar** on each side of the **sail**.

### (c) HULL SPARS

A **spar** attached to the **hull**.

#### (i) BOWSPRIT

A **hull spar** extending forward to **connect rigging** and/or the **tack** of a **headsail**, **headsails** or a **spinnaker**.

#### (ii) BUMKIN

A **hull spar** extending aft of the **hull** to **connect rigging**.

#### (iii) DECK SPREADER

A **hull spar** extending transversely to **connect standing rigging**.

#### (iv) OUTRIGGER

A **hull spar** extending transversely **connected** to a **sheet**.

### (d) OTHER SPARS

Other **spar** types include their **rigging**, but not **running rigging**.

Other **Spar** Types:

#### (i) SPINNAKER POLE

A **spar** attached to the **mast spar** and **connected** to a **spinnaker guy**.

#### (ii) WHISKER POLE

A **spar** attached to the **mast spar** and **connected** to a **headsail clew**.

#### (iii) GAFF

A **spar** attached at one end to a **mast spar** to **connect** the **peak**, **throat** and/or **head** of a quadrilateral **sail**.

#### (iv) SPRIT

## PART 2 DEFINITIONS

---

A **spar** attached at one end to a **mast spar** or a **hull** to **connect** only the **peak** of a quadrilateral **sail**.

(v) YARD

A **spar** hoisted on a **mast spar** at a point between its ends to **connect** the **head** of a quadrilateral **sail** or the **luff** of a lateen **sail**.

(vi) BAR

A **spar** to **connect** and control a **kite**.

(vii) JOCKEY POLE

A **spar** attached to the **hull** or **mast spar**, extending transversely and **connected** to a **spinnaker guy**.

### F.1.5 Spreader

Equipment used to brace a **spar**, attached at one end to the **spar** and **connected** at the other end to **standing rigging**, working in compression when in use.

### F.1.6 Rigging

Any equipment attached and/or **connected** at one or both ends to **spars**, **sails** or other **rigging** and capable of working in tension only. Includes associated **fittings** which are not permanently fixed to a **hull**, **spar** or **spreader**.

### F.1.7 Rigging Types

(a) STANDING RIGGING

**Rigging** used to support a **mast spar** or **hull spar**. It may be adjustable but is not detached when *racing* except as below:

**Standing Rigging** types:

(i) SHROUD

**Rigging** used to provide transverse support for a **mast spar** or **hull spar** and which may also provide longitudinal support.

(ii) STAY

**Rigging** mainly used to provide longitudinal support for a **mast spar** or **hull spar** or a **sail** which may be detached while *racing*.

(iii) FORESTAY

**Rigging** used to provide forward support for a **mast spar**.

(b) RUNNING RIGGING

**Rigging** primarily used to adjust a **spar**, a **sail** or a **hull appendage**.

**Running Rigging** types:

(i) HALYARD

**Rigging** used to hoist a **sail**, **spar**, flag or a combination thereof.

(ii) BACKSTAY

**Rigging** mainly used to provide aft support for a **mast spar** above the **upper limit mark**.

## PART 2 DEFINITIONS

---

(iii) **RUNNING BACKSTAY**

**Rigging** used to provide aft support for a **mast spar** at a point, or points, between the **upper limit mark** and the **forestay rigging point**.

(iv) **CHECKSTAY**

**Rigging** used to provide aft support for a **mast spar** at a point, or points, between the **lower limit mark** and the **forestay rigging point**.

(v) **OUTHAUL**

**Rigging** used to trim the **clew** of a **sail** along a **boom spar**.

(vi) **SHEET**

**Rigging** used to trim the **clew** of a **sail**, or a **boom spar**.

(vii) **SPINNAKER GUY**

**Rigging** used to trim the **tack** of a **spinnaker**.

(viii) **FLYING LINES**

**Rigging** used to trim a **kite**.

(ix) **FRONT LINES**

**Flying lines** used to transfer the power from a **kite** to the **crew**.

(x) **BACK LINES**

**Flying lines** used for steering a **kite**.

(xi) **VANG**

Equipment connected to the **boom** and used to control the angle between the **mast** and the **boom**. The term includes Gnav variations.

(c) **OTHER RIGGING**

(i) **TRAPEZE**

**Rigging** attached to a **mast spar** used to support a single **crew** member.

### F.1.8 Foretriangle

The area formed by the foreside of the foremost **mast spar**, the foremost **forestay** and the deck including any superstructure.

### F.1.9 Limit Mark Width

The minimum width measured in the length direction of the **spar**.

## F.2 MAST MEASUREMENT DEFINITIONS

### F.2.1 Mast Limit Marks

(a) **LOWER LIMIT MARK**

The **limit mark** for the setting of a **boom spar** or **sail**.

(b) **UPPER LIMIT MARK**

The **limit mark** for the setting of a **sail**.

### F.2.2 Mast Measurement Points

(a) **MAST DATUM POINT**



## PART 2 DEFINITIONS

---

The point on the **mast** specified in the **class rules** used as a datum for measurement.

(b) **HEEL POINT**

The lowest point on the **spar** and its **fittings**.

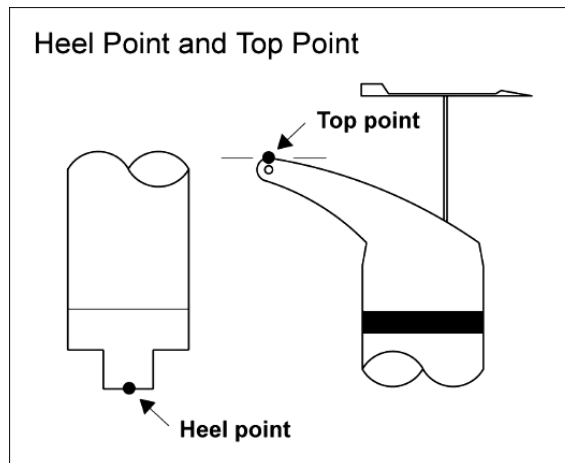

(c) **TOP POINT**

The highest point on the **spar** and its **fittings**.

(d) **LOWER POINT**

The highest point of the **lower limit mark** at the aft edge of the **spar**.

(e) **UPPER POINT**

The lowest point of the **upper limit mark** at the aft edge of the **spar**.

### F.2.3 Mast Dimensions

See H.4.

(a) **MAST LENGTH**

The distance between the **heel point** and the **top point**.

(b) **LOWER POINT HEIGHT**

The distance between the **mast datum point** and the **lower point**.

(c) **UPPER POINT HEIGHT**

The distance between the **mast datum point** and the **upper point**.

(d) **MAINSAIL LUFF MAST DISTANCE**

The distance between the **lower point** and the **upper point**.

(e) **RIGGING POINT \***

When **rigging** is attached:

**BY HOOK TERMINAL:** The lowest point of the hook where it intersects the **spar**, extended as necessary.

**BY TANG WITH THROUGH FIXING:** The lowest point of the **spar** through fixing where it intersects the **spar**.

**IN OTHER WAYS:** The intersection of the outside of the **spar**, extended as necessary, and the centreline of the **rigging**.

## PART 2 DEFINITIONS

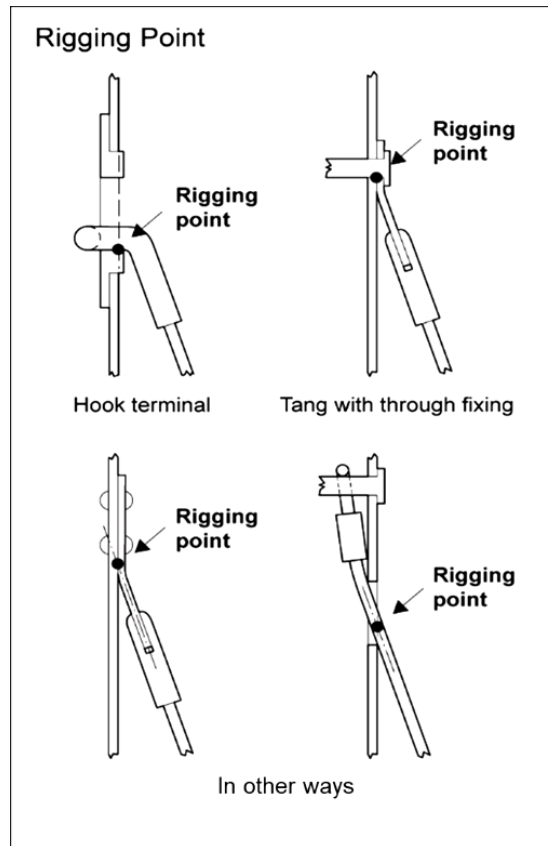

(f) FORESTAY HEIGHT \*

The distance between the **mast datum point** and the **rigging point** or the **top point** whichever is the lowest.

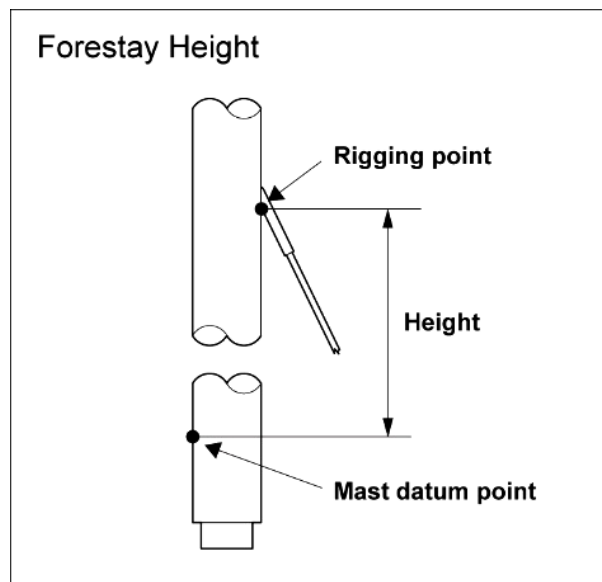

(g) SHROUD HEIGHT \*

The distance between the **mast datum point** and the **rigging point**.

## PART 2 DEFINITIONS

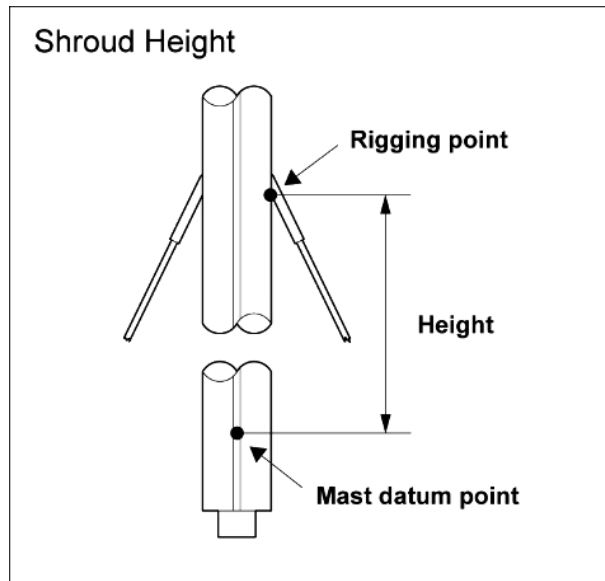

(h) BACKSTAY HEIGHT \*

The distance between the **mast datum point** and the **rigging point** or the **top point** whichever is the lowest.

(i) CHECKSTAY HEIGHT \*

The distance between the **mast datum point** and the **rigging point**.

(j) TRAPEZE HEIGHT \*

The distance between the **mast datum point** and the **rigging point**.

(k) HEADSAIL HOIST HEIGHT \*

The distance between the **mast datum point** and the intersection of the **spar** and the lower edge of the **headsail halyard**, when at 90° to the **spar**, each extended as necessary.

(l) SPINNAKER HOIST HEIGHT \*

The distance between the **mast datum point** and the intersection of the **spar** and the lower edge of the **spinnaker halyard**, when at 90° to the **spar**, each extended as necessary.

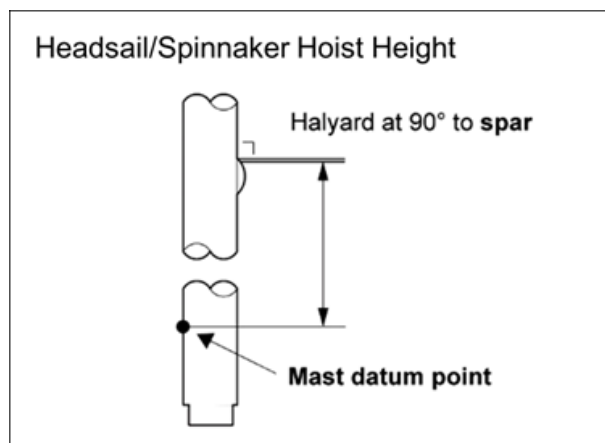

(m) MAST SPAR CURVATURE

The greatest distance between the **spar** and a straight line from the **upper point** to the **lower point** taken at 90° to the straight line when the **spar** is resting on one side.

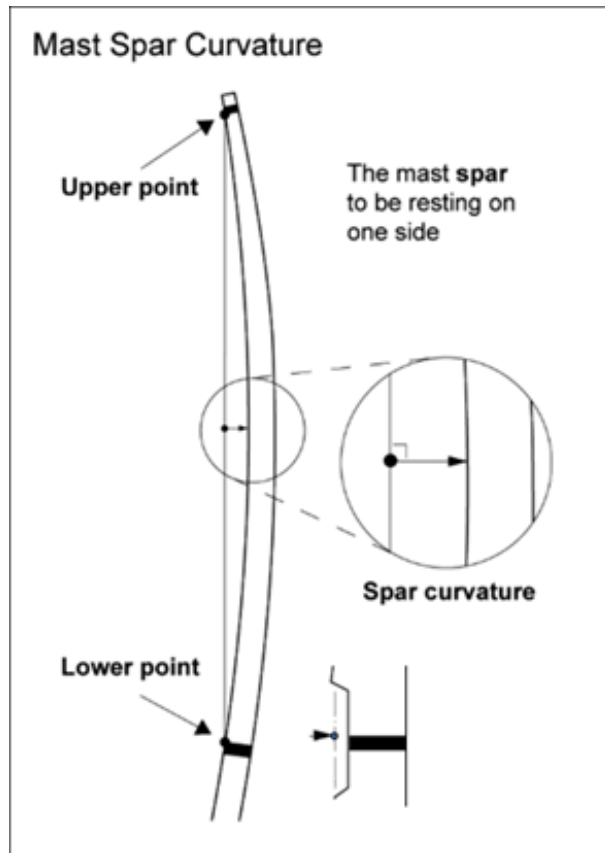

(n) MAST SPAR DEFLECTION

The difference in distance, at a specified distance from the **mast datum point**, between

the **spar**

and a straight line from the **upper point** to the **lower point**

taken at 90° to the straight line with and without a specified load at the specified distance when the **spar** is horizontal at and supported at these points.

(i) FORE-AND-AFT: Measured with the aft edge up.

(ii) TRANSVERSE: Measured with one side up.

See H.4.5.

## PART 2 DEFINITIONS

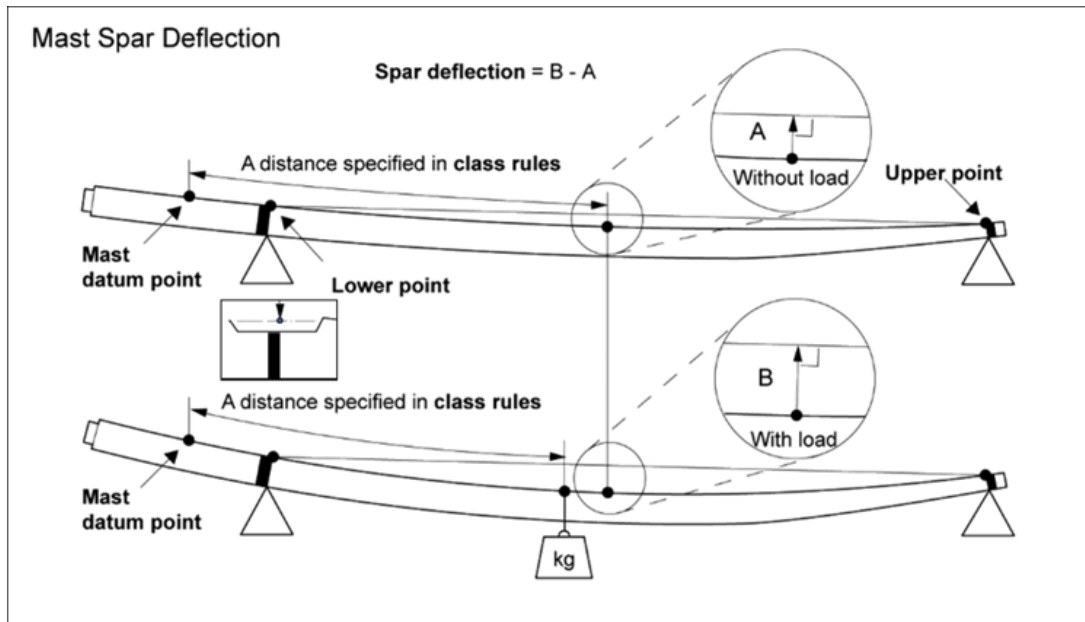

(o) **MAST SPAR CROSS SECTION**

- (i) **FORE-AND-AFT**: The fore-and-aft dimension, including any **sail track**, at a specified distance from the **mast datum point**.
- (ii) **TRANSVERSE**: The transverse dimension, at a specified distance from the **mast datum point**.

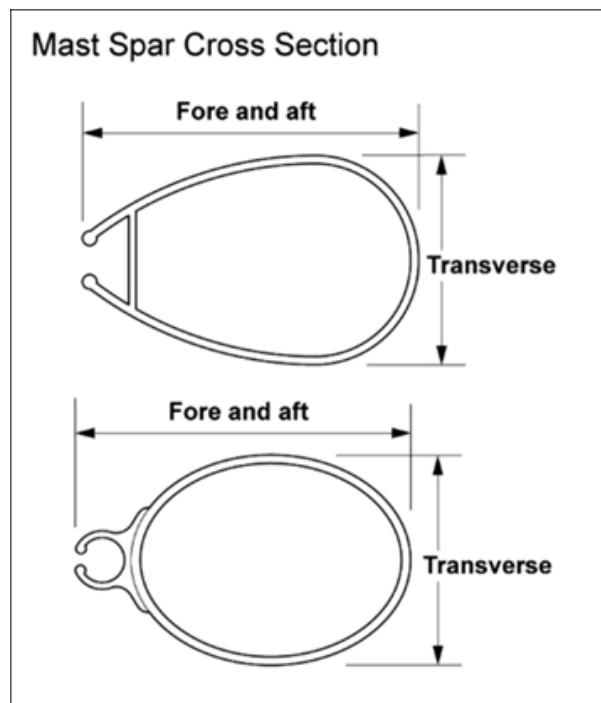

(p) **MAST WEIGHT**

The weight of the **mast**.

(q) **MAST TIP WEIGHT**

The weight at the **upper point** when the **mast** is horizontal and supported at the **lower point**.

See H.4.6.

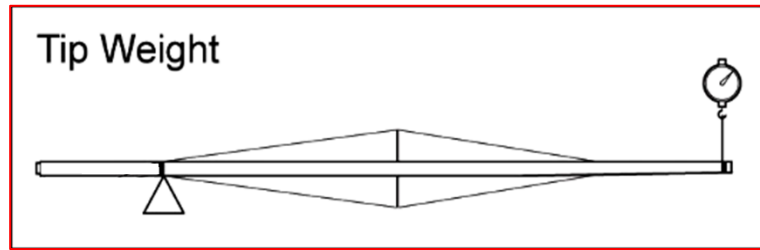

(r) MAST CENTRE OF GRAVITY HEIGHT

The distance from the **mast datum point** to centre of gravity of the **mast**.

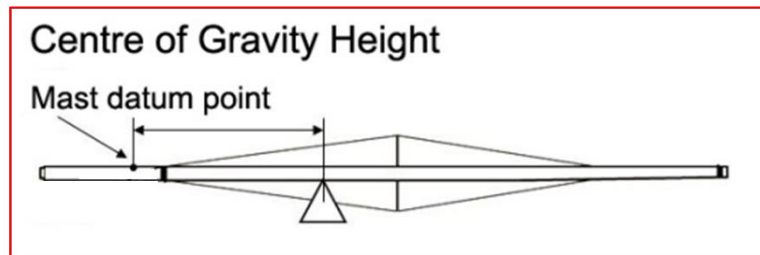

F.2.4 Mast Fittings

(a) SPREADER \*

- (i) LENGTH: The distance between the inner edge of the **shroud** at the lower edge of the **spreader** and the intersection of the lower edge of the **spreader**, extended as necessary, and the **mast spar**.

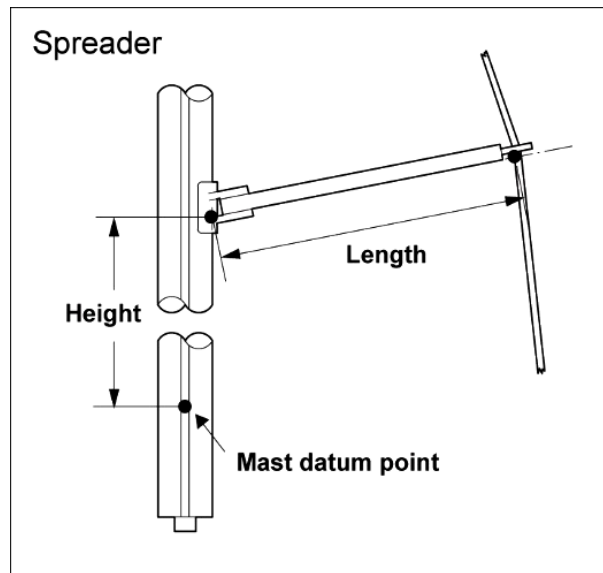

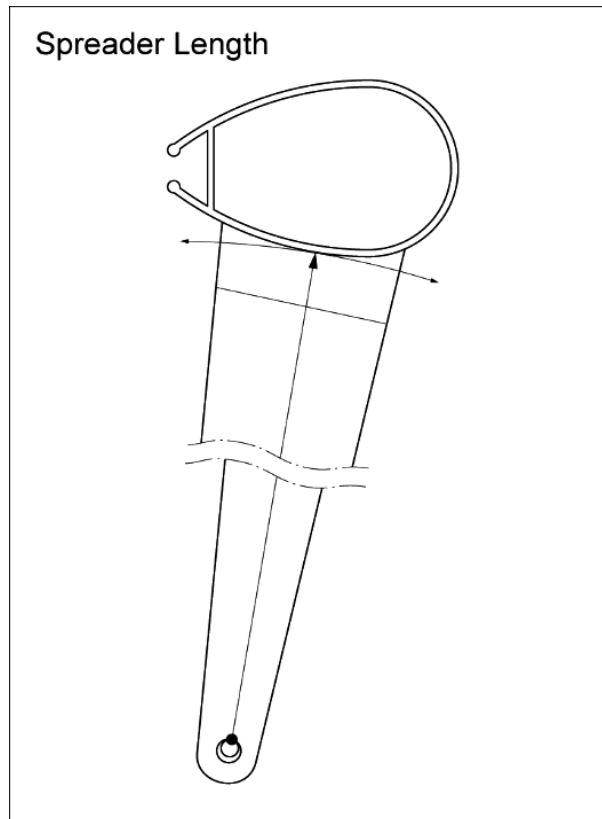

- (ii) **HEIGHT:** The distance between **mast datum point** and the intersection of the lower edge of the **spreader**, extended as necessary, and the **mast spar**.

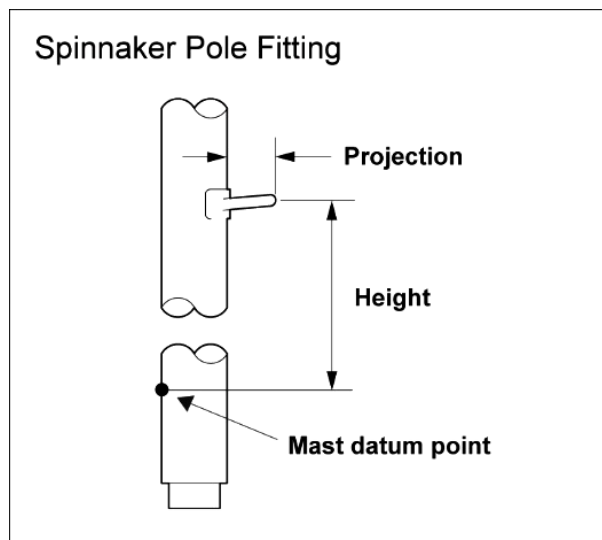

(b) **SPINNAKER POLE FITTING**

- (i) **HEIGHT:** The distance between the **mast datum point** and the centre of the highest bearing part of the **fitting**.
- (ii) **PROJECTION:** The shortest distance between the outermost point of the **fitting** and the **mast spar**.

### F.3 BOOM MEASUREMENT DEFINITIONS

#### F.3.1 Boom Measurement Points

(a) OUTER POINT

The point on the boom **outer limit mark**, at the upper edge of the **boom spar**, nearest the fore end of the **spar**.

#### F.3.2 Boom Limit Marks

(a) OUTER LIMIT MARK

The **limit mark** for the setting of a **mainsail**, **foresail** or **mizzen**.

#### F.3.3 Boom Dimensions

See H.4.

(a) OUTER POINT DISTANCE

The distance between the **outer point** and the aft edge of the **mast spar**, with the **boom spar** on the **mast spar** centreplane and at 90° to the **mast spar**.

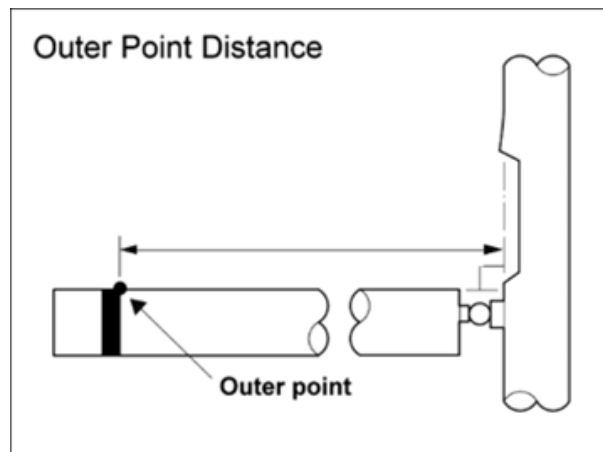

(b) BOOM SPAR CURVATURE

The greatest distance between the **spar** and a straight line from the uppermost fore end of the **spar** to the **outer point** or, where there is no **outer point**, to the uppermost aft end of the **spar**, taken at 90° to the straight line when the **spar** is resting on one side.

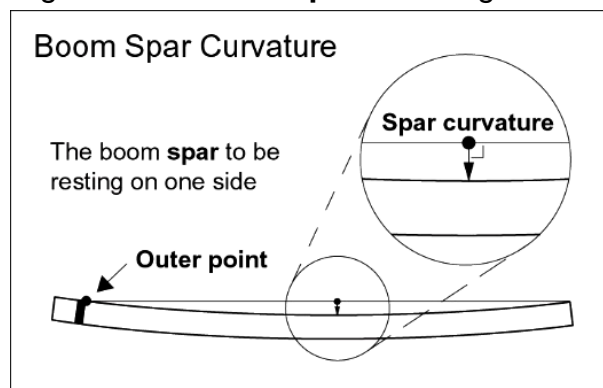

(c) BOOM SPAR DEFLECTION

The difference in distance, at a specified distance from the **outer point**, between the **spar**



## PART 2 DEFINITIONS

and a straight line from the **outer point** to the top of the fore end of the **spar**

taken at 90° to the straight line and with and without a specified load at the specified distance when the **spar** is horizontal and supported at these points.

(i) VERTICAL: Measured with the top edge up.

(ii) TRANSVERSE: Measured with one side up.

See H.4.5.

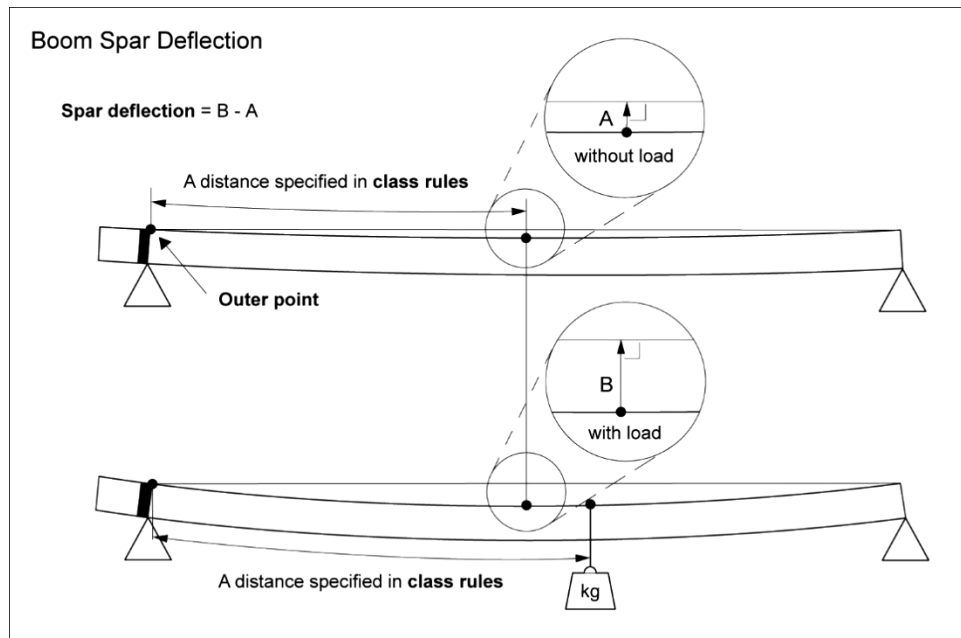

### (d) BOOM SPAR CROSS SECTION

(i) VERTICAL: The vertical dimension, including any **sail track**, at a specified distance from the **outer point**.

(ii) TRANSVERSE: The transverse dimension at a specified distance from the **outer point**.

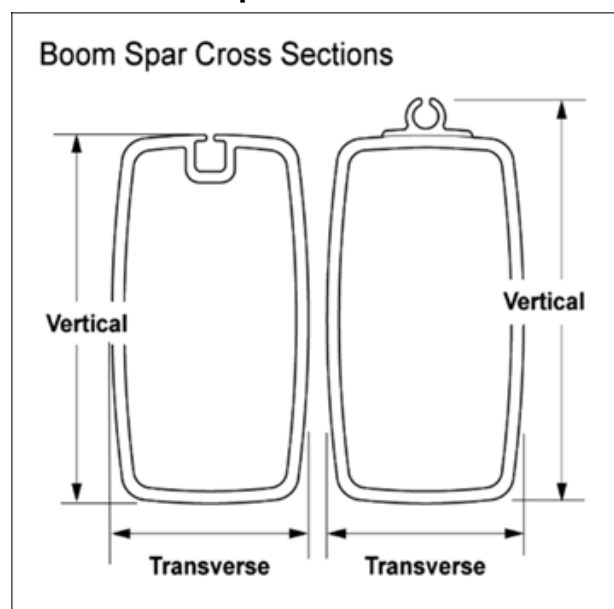

### (e) BOOM WEIGHT

The weight of the **boom**.

## F.4 SPAR MEASUREMENT DIMENSIONS

See H.4.

### (a) SPAR LENGTH

The distance between the ends of the **spar**.

### (b) SPAR CROSS SECTION

The sectional dimensions at specified distances from an end of the **spar**.

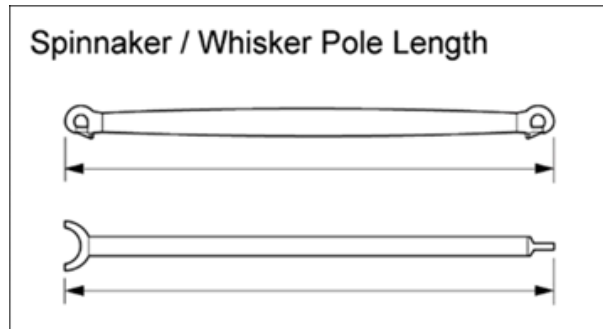

### (c) SPAR WEIGHT

The weight of the **spar**.

## F.5 BOWSPRIT MEASUREMENT DEFINITIONS

### F.5.1 Bowsprit Measurement Points

#### (a) BOWSPRIT INNER POINT

The point of the **bowsprit inner limit mark**, at the upper edge of the **spar**, nearest the outboard end of the **spar**.

#### (b) BOWSPRIT OUTER POINT

The point of the **bowsprit outer limit mark**, at the upper edge of the **spar**, nearest the inner end of the **spar**, or the outboard end of the **spar** when there is no **outer limit mark**.

### F.5.2 Bowsprit Limit Marks

#### (a) BOWSPRIT INNER LIMIT MARK

The **limit mark** for the setting of the **spar**.

#### (b) BOWSPRIT OUTER LIMIT MARK

The **limit mark** for the setting of a **headsail**.

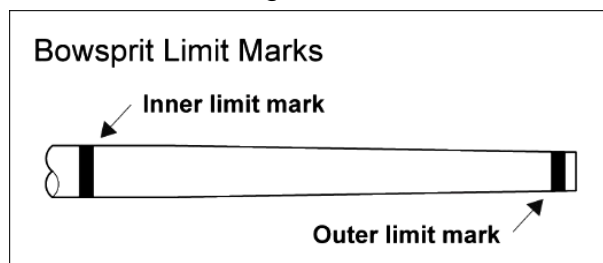

### F.5.3 Bowsprit Dimensions

See H.4.

#### (a) BOWSPRIT POINT DISTANCE

The distance between the **bowsprit inner point** and the **bowsprit outer point**.

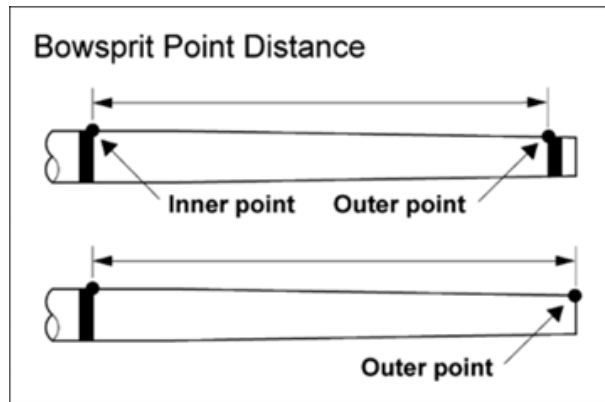

- (b) **BOWSPRIT SPAR CROSS SECTION**  
The sectional dimensions at specified positions.
- (c) **BOWSPRIT WEIGHT**  
The weight of the **bowsprit**.

## F.6 FORETRIANGLE MEASUREMENT DEFINITIONS

### F.6.1 Foretriangle Dimensions

- (a) **FORETRIANGLE BASE**  
The longitudinal distance between the intersection of the fore side of the **mast spar**, extended as necessary, and the deck including any superstructure, and the intersection of the centreline of the **forestay**, extended as necessary, and the deck, or **bowsprit spar**.  
See H.3.4.

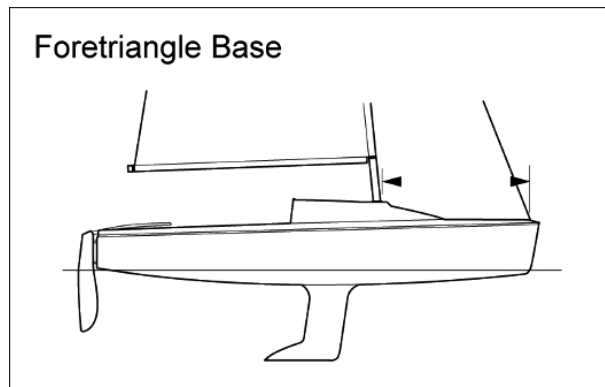

- (b) **FORETRIANGLE HEIGHT**  
The distance between the intersection of the **sheer** and the fore side of the **mast spar**, extended as necessary, and the **forestay rigging point**.  
See H.4.

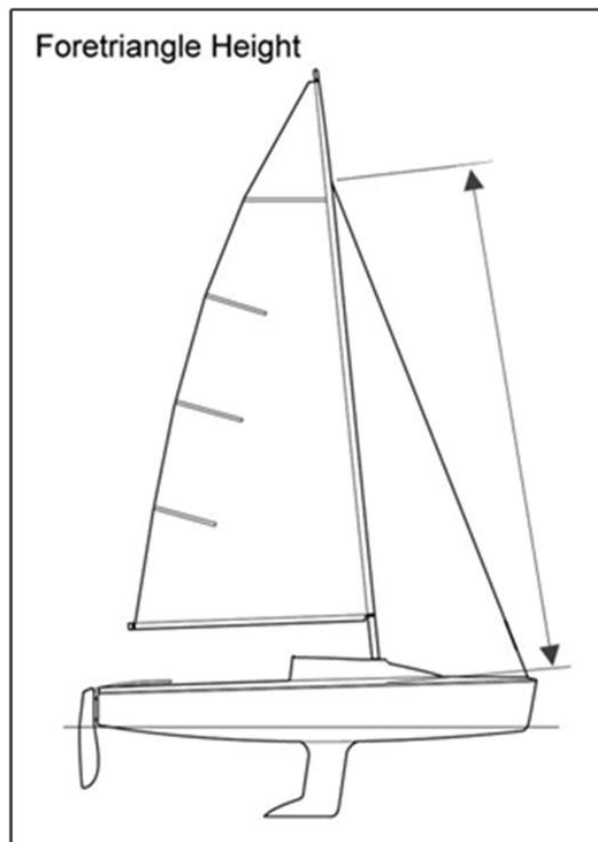

(c) FORETRIANGLE AREA

Half the product of the **foretriangle base** and the **foretriangle height**.

## F.7 SAIL SETTING MEASUREMENT DEFINITIONS

### F.7.1 Spinnaker Tack Distance

The maximum longitudinal distance from the fore side of the **mast spar** to the end of the longest **spinnaker pole** or the **bowsprit outer point** measured on or near the **boat centreplane**; or the longitudinal distance from the fore side of the **mast spar**, extended as necessary, and the deck including any superstructure, forward to the **spinnaker tack point** on deck; whichever is the greatest.

## Section G – Sail Definitions

### Subsection A – Trilateral Sails

Definitions relating to **sails** with only three **sail edges**:

“MAINSAIL” also applies to **foremast sail** and **mizzen**.

“HEADSAIL” also applies to “jib”, “genoa” and “solent”.

“SPINNAKER” applies to symmetric and asymmetric (“gennaker”) sails .

#### G.1 GENERAL SAIL TERMS

##### G.1.1 Sail

An item of equipment, used to propel the **boat**. It includes any of the following added parts:

**sail reinforcements**

**batten pockets** and associated **fittings**

**windows**

**stiffening**

**tabling**

**sail edge** ropes and wires

**attachments**

other parts as permitted by **class rules**.

##### G.1.2 Set Flying

A **sail** set with no **sail edge** attached to the **rig**.

##### G.1.3 Sail Types

(a) MAINSAIL

A **sail** with the **luff** attached to the **mainmast spar**. The lowest of the **sails** if more than one **sail** with the **luff** set to that **spar**.

(b) FOREMAST SAIL

A **sail** with the **luff** attached to the **foremast spar**. The lowest of the **sails** if more than one **sail** with the **luff** set to that **spar**.

(c) MIZZEN

A **sail** with the **luff** attached to the **mizzenmast spar**. The lowest of the **sails** if more than one **sail** with the **luff** set to that **spar**.

(d) HEADSAIL

A **sail** set forward of the **mast spar** or of the foremost **mast spar** if more than one **mast**, where the measurement between the **half luff point** and the **half leech point** is less than 75% of the **foot length**.

(e) KITE

A **sail connected** to the **bar**.

(f) SPINNAKER

A **sail** set forward of the **mast spar** or of the foremost **mast spar** if more than one **mast**, where the measurement between the **half luff point** and the **half leech point** is equal or greater than 75% of the **foot length**.

### G.1.4 Sail Construction

(a) BODY OF THE SAIL

The **sail** excluding the areas where parts are added as per G.1.1.

(b) PLY

A sheet of sail material.

(c) SOFT SAIL

A **sail** where the **body of the sail** is capable of being folded flat in any direction without damaging any **ply** other than by creasing.

(d) WOVEN PLY

A **ply** which, when torn, can be separated into fibres without leaving evidence of a film.

(e) LAMINATED PLY

A **ply** made up of more than one layer.

(f) SINGLE-PLY SAIL

A **sail**, except at **seams**, where all parts of the **body of the sail** consist of only one **ply**.

(g) DOUBLE LUFF SAIL

A **sail** with more than one **luff**, or a **sail** passing around a **spar** and attached back on itself.

(h) SEAM

Overlap where two or more **ply** forming the **body of the sail** are joined.

(i) DART

An overlap formed at a **sail edge** by overlapping the **ply** edges of a cut in the **body of the sail**.

(j) TUCK

Overlap where a **ply** is folded and joined.

(k) BATTEN POCKET

**Ply** to form a pocket for a batten.

(l) SAIL OPENING

Any opening other than openings created by **attachments** or **batten pockets**.

(m) WINDOW

A predominantly transparent **ply** in the **body of the sail**.

(n) STIFFENING

Corner boards and battens.

### (o) ATTACHMENTS

cringles  
straps  
hanks  
slides  
adjustment eyes  
adjustment points  
reefing eyes  
reefing points, and  
blocks and their **fastenings**.

See H.5.3.

### (p) SAIL EDGE SHAPE

The shape of a **sail edge** as a comparison with a straight line between

**corner points** or,

in the case of a **leech** other than of a gennaker or **spinnaker**, between the **clew point** and the **aft head point**.

## G.2 SAIL EDGES

### G.2.1 Foot

The bottom edge.

### G.2.2 Leech

The aft edge.

### G.2.3 Luff

The fore edge.

### G.2.4 Sail Leech Hollow

Concavity in the shape of a **leech** between adjacent **batten pockets**, or a **batten pocket** and the adjacent **corner point**, or in the case of a **mainsail**, **foremast sail**, **mizzen** or a **headsail** other than a **spinnaker** or a gennaker, between the **aft head point** and the adjacent **batten pocket**.

## G.3 SAIL CORNERS

### G.3.1 Clew

The region where the **foot** and the **leech** meet.

### G.3.2 Head

The region at the top.

### G.3.3 Tack

The region where the **luff** and the **foot** meet.

## PART 2 DEFINITIONS

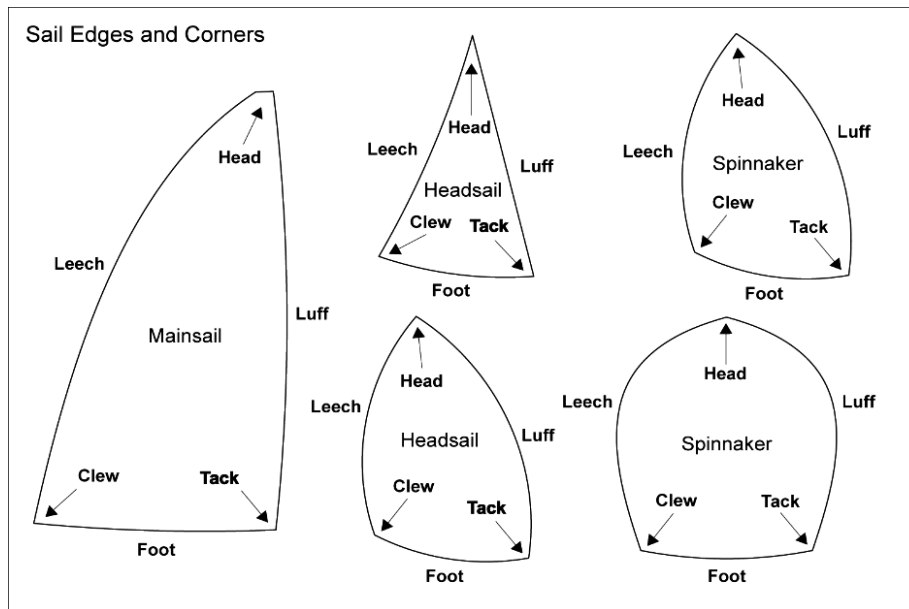

### G.4 SAIL CORNER MEASUREMENT POINTS \*

#### G.4.1 Clew Point

The intersection of the **foot** and the **leech**, each extended as necessary to bridge a cut-out or a rounded corner.

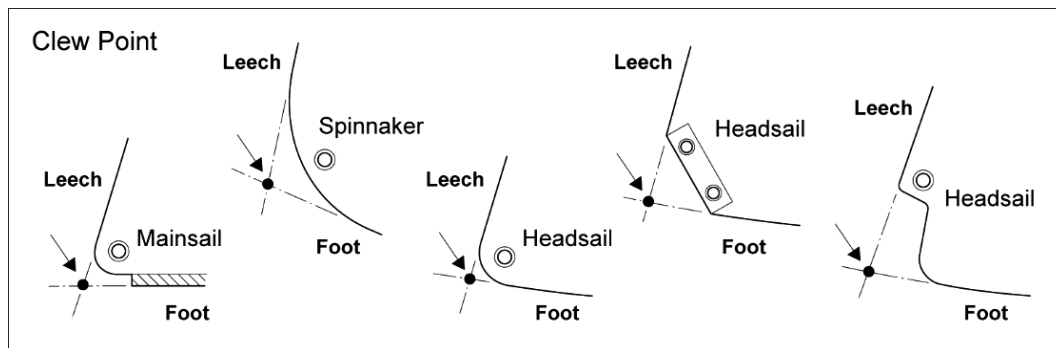

#### G.4.2 Head Point

- MAINSAIL: The intersection of the **luff**, extended as necessary, and the line through the highest point of the **sail** at 90° to the **luff**.
- HEADSAIL: The intersection of the **luff**, extended as necessary, and the line at 90° to the **luff** passing through the highest point of the **sail** excluding **attachments** and any luff tape / **tabling**.
- SPINNAKER: The intersection of the **luff** and the **leech**, extended as necessary to bridge a cut-out or a rounded corner.

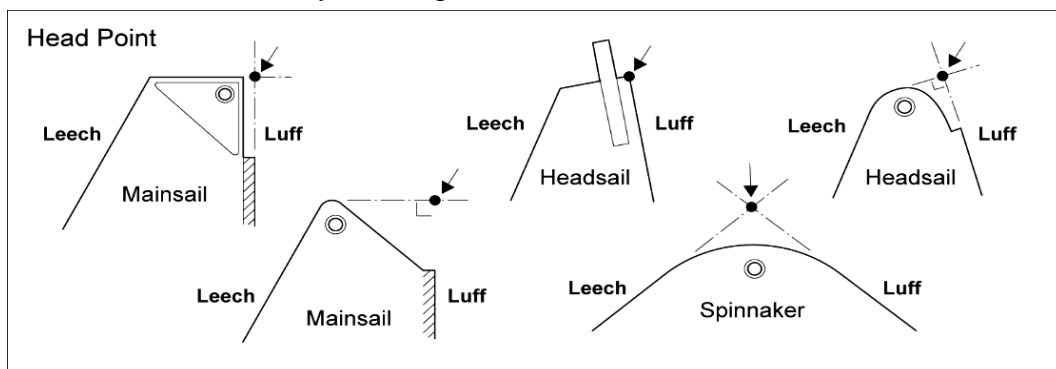



## PART 2 DEFINITIONS

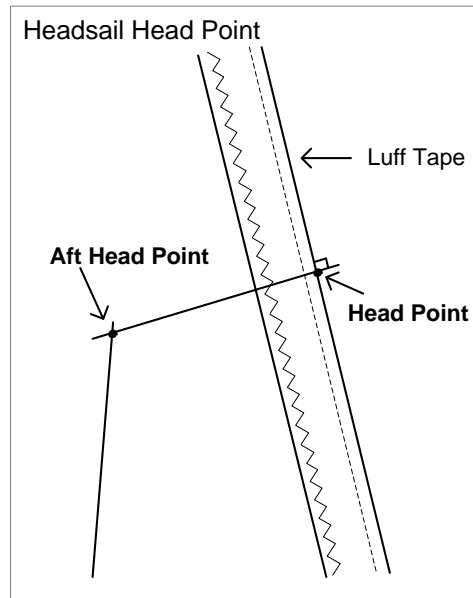

### G.4.3 Tack Point

The intersection of the **foot** and the **luff**, each extended as necessary to bridge a cut-out or a rounded corner.

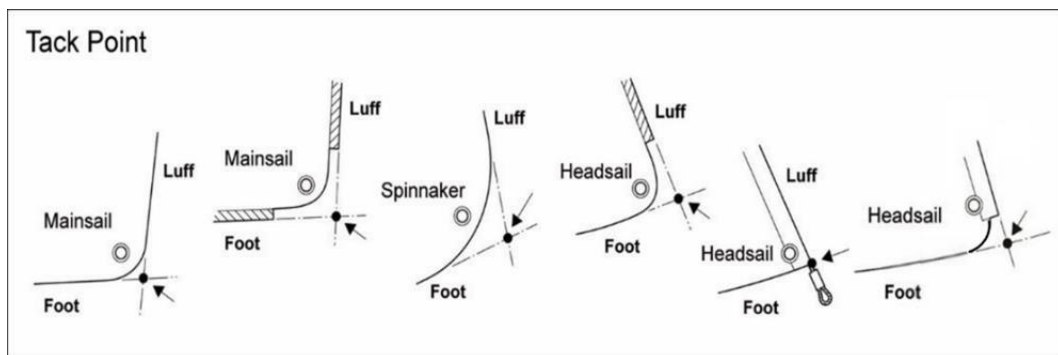

## G.5 OTHER SAIL MEASUREMENT POINTS

### G.5.1 Quarter Leech Point

The point on the **leech** equidistant from the **half leech point** and the **clew point**.

### G.5.2 Half Leech Point

The point on the **leech** equidistant from the **head point** and the **clew point**.

### G.5.3 Three-Quarter Leech Point

The point on the **leech** equidistant from the **head point** and the **half leech point**.

### G.5.4 Seven-Eighths Leech Point

The point on the **leech** equidistant from the **head point** and the **three-quarter leech point**.

## PART 2 DEFINITIONS

### G.5.5 Upper Leech Point

The point on the **leech** at a specified distance from the **head point**.

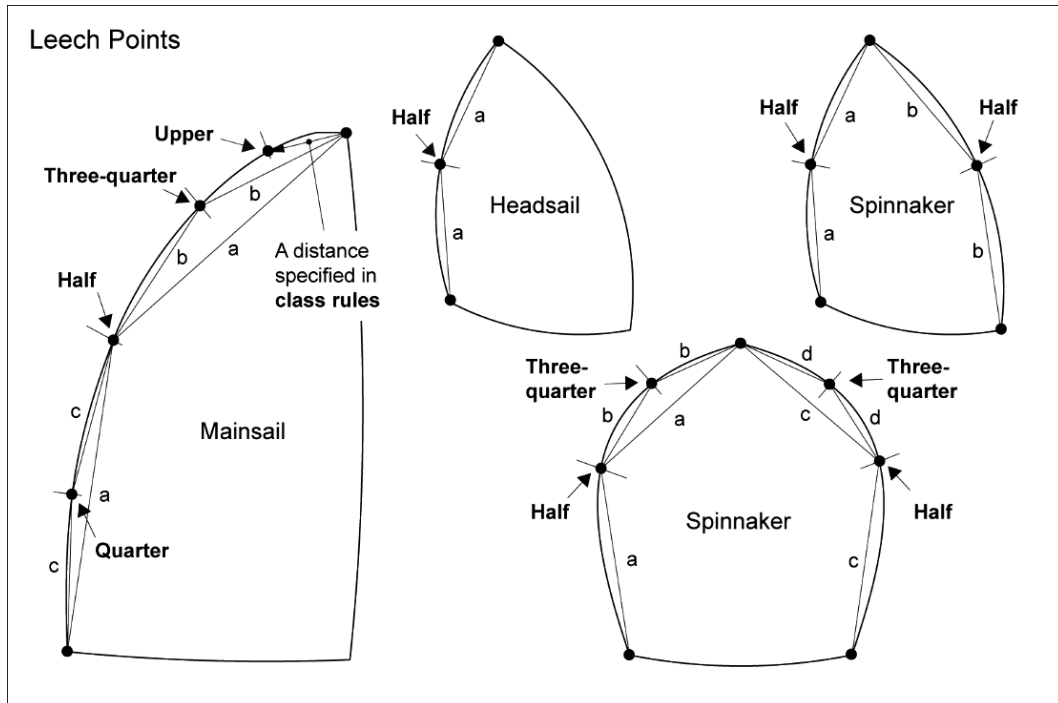

### G.5.6 Aft Head Point \*

MAINSAIL and HEADSAIL: The intersection of the **leech** extended as necessary to bridge a cut-out or a rounded corner and the line through the **head point** at 90° to the **luff**.

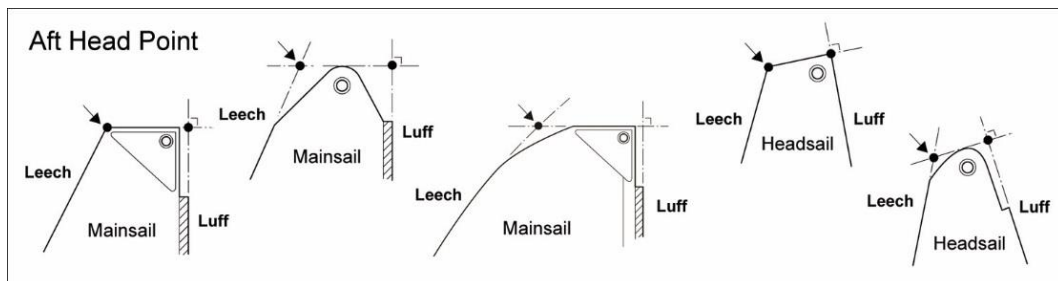

### G.5.7 Quarter Luff Point

The point on the **luff** equidistant from the **half luff point** and the **tack point**.

### G.5.8 Half Luff Point

The point on the **luff** equidistant from the **head point** and the **tack point**.

### G.5.9 Three-Quarter Luff Point

The point on the **luff** equidistant from the **head point** and the **half luff point**.

### G.5.10 Seven-Eighths Luff Point

The point on the **luff** equidistant from the **head point** and the **three-quarter luff point**.

## PART 2 DEFINITIONS

---

### G.5.11 Upper Luff Point

The point on the **luff** at a specified distance from the **head point**.

### G.5.12 Mid Foot Point

The point on the **foot** equidistant from the **tack point** and the **clew point**.

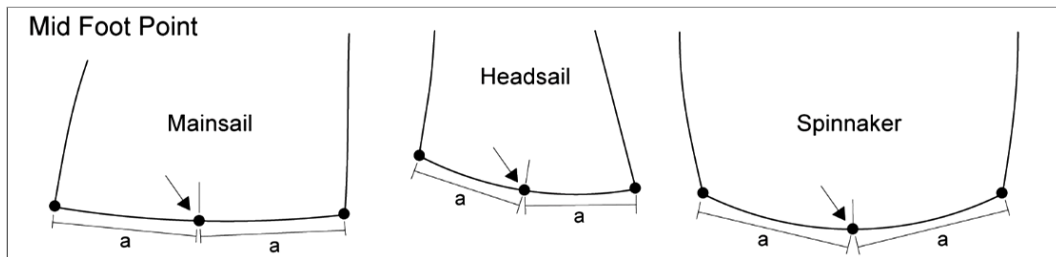

## G.6 SAIL REINFORCEMENT

### G.6.1 Primary Reinforcement

An unrestricted number of additional layers of **ply** of permitted material:

- at a corner
- at an adjustment point
- at a reefing point adjacent to the **luff**
- at a reefing point adjacent to the **leech**
- at a **sail** recovery point
- where permitted by the **class rules**

### G.6.2 Secondary Reinforcement

Not more than two additional layers of **ply** of permitted material each not thicker than the maximum thickness of the **ply** of the **body of the sail**:

- at a corner
- at an adjustment point
- at a reefing point
- at a **sail** recovery point
- to form a **flutter patch**
- to form a **chafing patch**
- to form a **batten pocket patch**
- where permitted by the **class rules**

## PART 2 DEFINITIONS

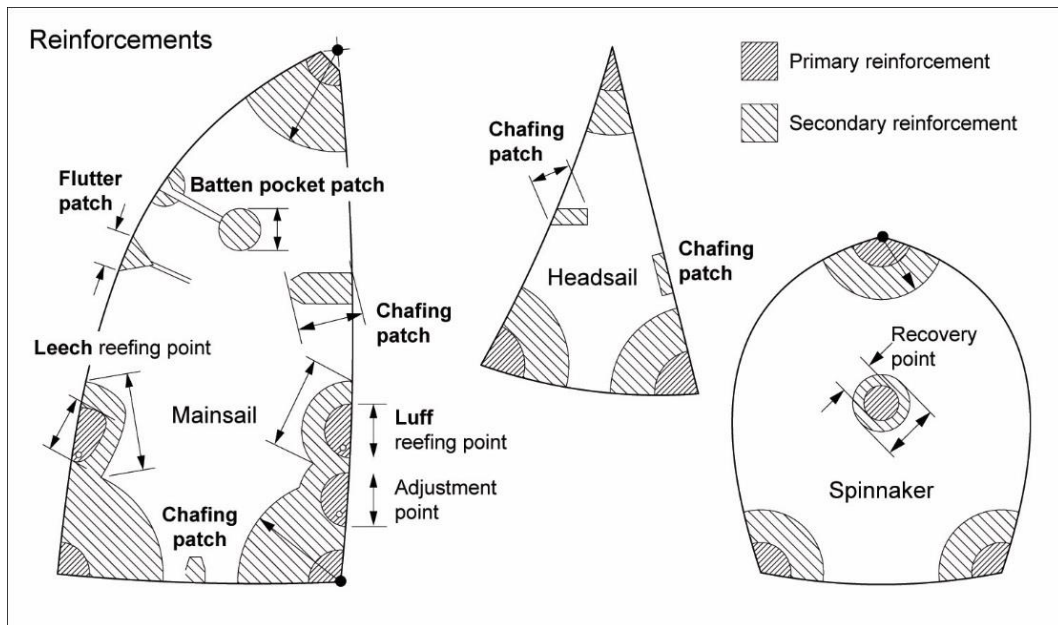

### G.6.3 Tabling

Additional **ply** and/or folded **ply** overlap(s) at a **sail edge**.

### G.6.4 Batten Pocket Patch

**Secondary reinforcement** at an end of a **batten pocket**.

### G.6.5 Chafing Patch

**Secondary reinforcement** where a **sail** can touch a **spreader**, **stanchion**, **shroud** or **spinnaker pole**.

### G.6.6 Flutter Patch

**Secondary reinforcement** on the **leech** or the **foot** at the end of a **seam**.

## G.7 PRIMARY SAIL DIMENSIONS

See H.5.

### G.7.1 Foot Length

The distance between the **clew point** and the **tack point**.

### G.7.2 Leech Length

The distance between the **head point** and the **clew point**.

### G.7.3 Luff Length

The distance between the **head point** and the **tack point**.

## PART 2 DEFINITIONS

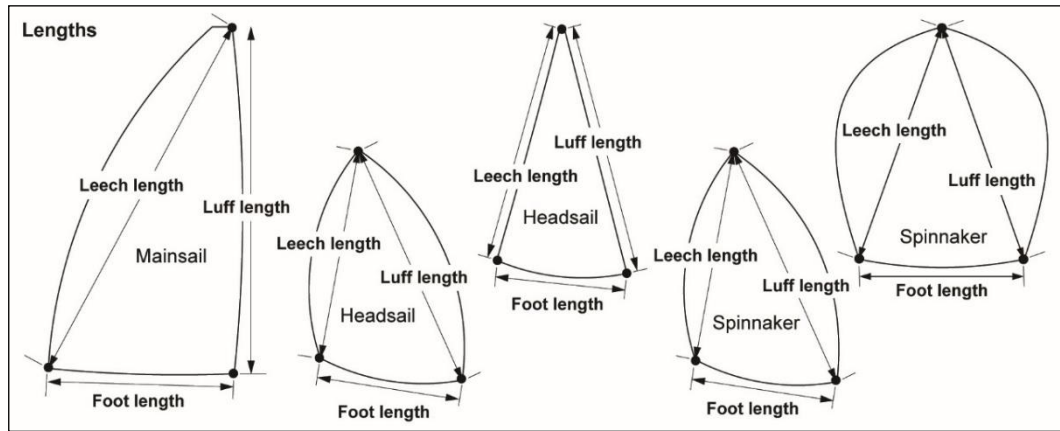

### G.7.4 Quarter Width

- (a) MAINSAIL and HEADSAIL: The shortest distance between the **quarter leech point** and the **luff**.
- (b) SPINNAKER: The distance between the **quarter luff point** and the **quarter leech point**.

### G.7.5 Half Width

- (a) MAINSAIL and HEADSAIL: The shortest distance between the **half leech point** and the **luff**.
- (b) SPINNAKER: The distance between the **half luff point** and the **half leech point**.

### G.7.6 Three-Quarter Width

- (a) MAINSAIL and HEADSAIL: The shortest distance between the **three-quarter leech point** and the **luff**.
- (b) SPINNAKER: The distance between the **three-quarter luff point** and **three-quarter leech point**.

### G.7.7 Seven-Eighths Width

- (a) MAINSAIL and HEADSAIL: The shortest distance between the **seven-eighths leech point** and the **luff**.
- (b) SPINNAKER: The distance between the **seven-eighths leech point** and the **seven-eighths luff point**.

### G.7.8 Upper Width

- (a) MAINSAIL and HEADSAIL: The shortest distance between the **upper leech point** and the **luff**.
- (b) SPINNAKER: The distance between the **upper luff point** and the **upper leech point**.

### G.7.9 Top Width

- (a) MAINSAIL and HEADSAIL: The distance between the **head point** and the **aft head point**.

## PART 2 DEFINITIONS

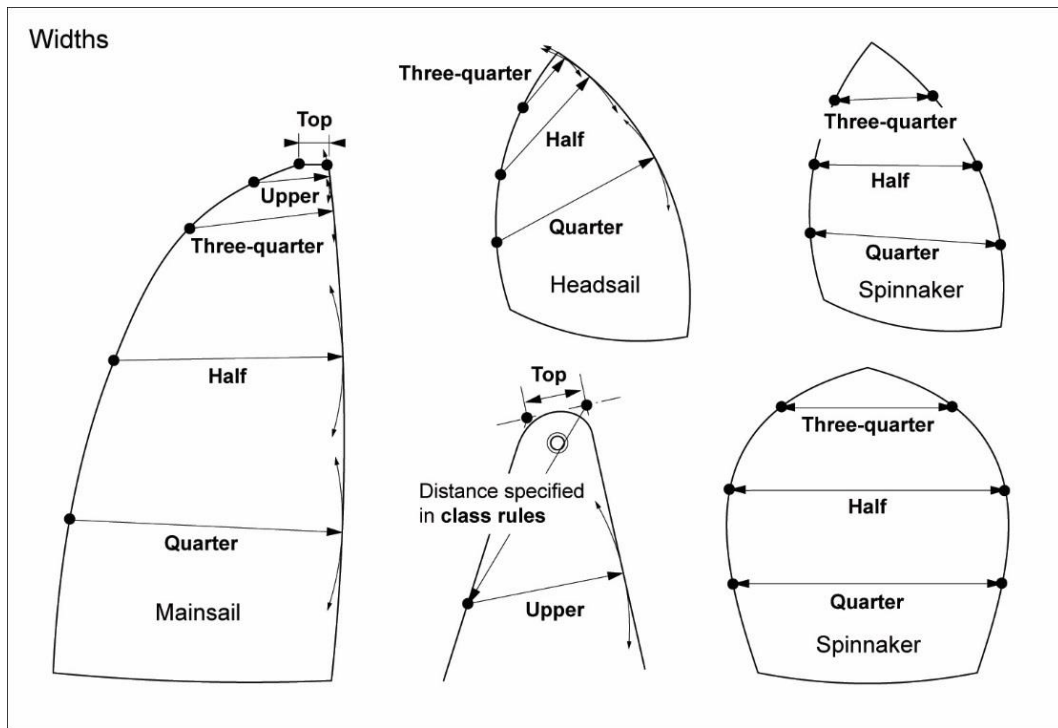

### G.7.10 Diagonals

- (a) **CLEW DIAGONAL:** The distance between the **clew point** and the **half luff point**.
- (b) **TACK DIAGONAL:** The distance between the **tack point** and the **half leech point**.

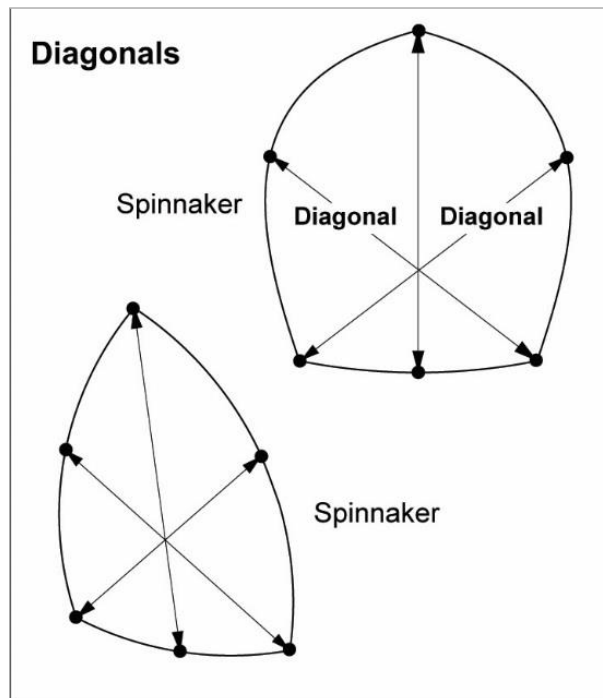

### G.7.11 Foot Median

The distance between the **head point** and the **mid foot point**.

## PART 2 DEFINITIONS

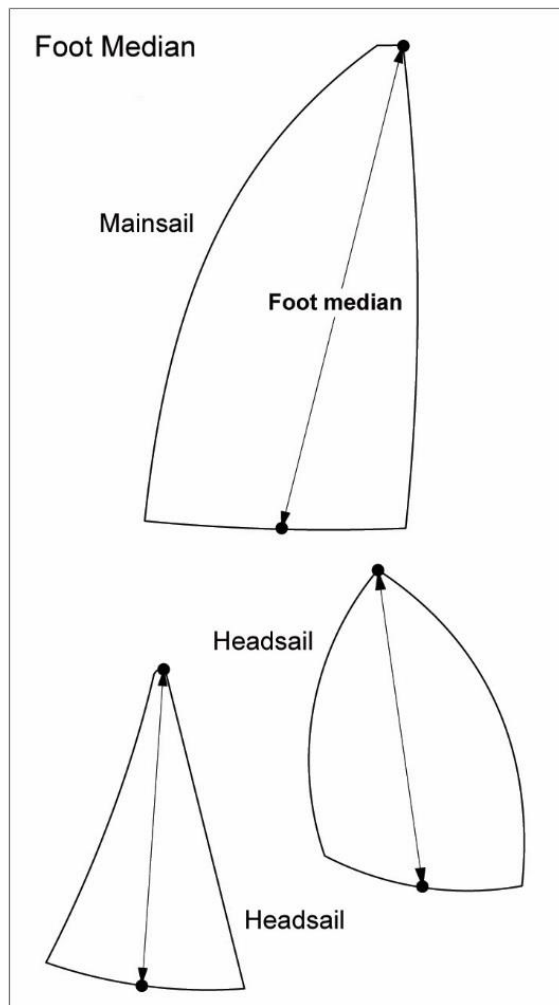

### G.7.12 Luff Perpendicular

The shortest distance between the **clew point** and the **luff**.

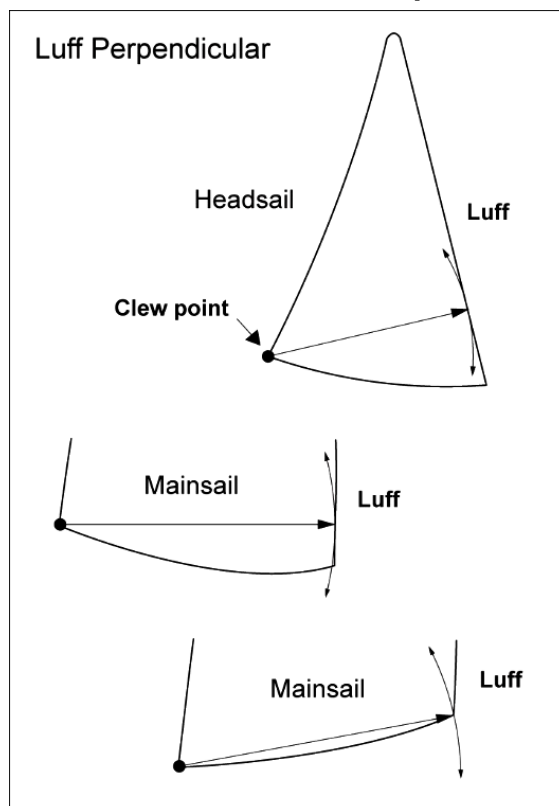

### G.7.13 Spinnaker Half Girth \*

The distance between a point on the **luff/leech** and a point on the **spinnaker** centreline, both of those points at specified distances from the **head point**.

## G.8 OTHER SAIL DIMENSIONS

See H.5.

### G.8.1 Batten Pocket Length

- (a) **INSIDE**: The greatest distance between the **sail edge** and the internal extreme end of the **batten pocket**, measured parallel to the pocket centreline. The effect of any elastic or other retaining device and any local widening for batten insertion shall be ignored.
- (b) **OUTSIDE**: The greatest distance between the **sail edge** and the external extreme end of the **batten pocket**, measured parallel to the pocket centreline. The effect of any local widening for batten insertion shall be ignored.

### G.8.2 Batten Pocket Width

- (a) **INSIDE**: The greatest distance between inside edges of the **batten pocket** measured at 90° to pocket centreline. Local widening for batten insertion shall be ignored.
- (b) **OUTSIDE**: The greatest distance between the outside edges of the **batten pocket** measured at 90° to the pocket centreline. Local widening for batten insertion shall be ignored.

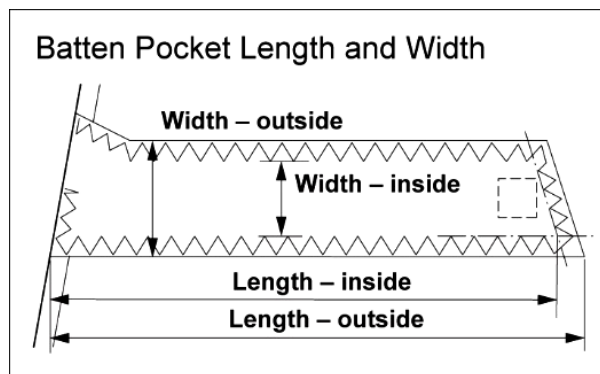

### G.8.3 Foot Irregularity

The maximum distance between the edges of the **foot** when first the **tack point** and then the **clew point** are superimposed on any part of the **foot**.



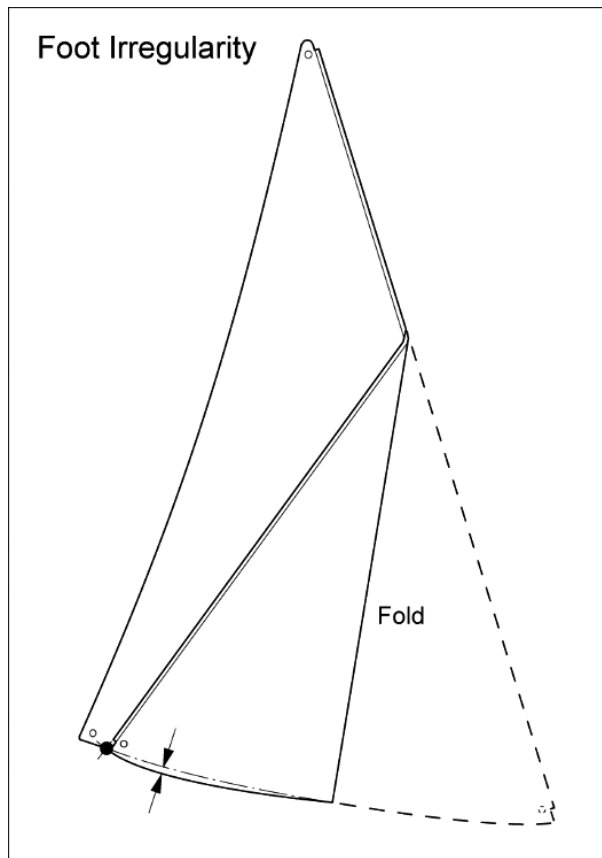

**G.8.4 Reinforcement Size**

- (a) AT A CORNER: The greatest distance measured from the **sail corner measurement point**.
- (b) TABLING WIDTH: The width of **tabling** measured at 90° to the **sail edge**.
- (c) ELSEWHERE: The greatest dimension of the **sail reinforcement**.

**G.8.5 Seam Width**

The width of a **seam** measured at 90° to the **seam**.

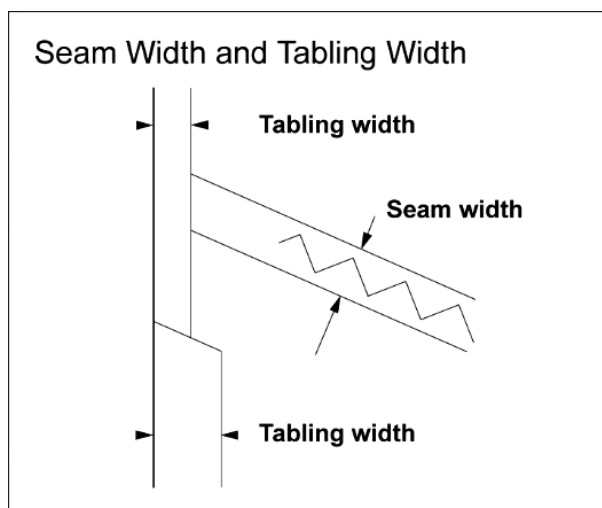

**G.8.6 Dart Width**

The width of a **dart** measured at 90° to the **dart centreline**.

## PART 2 DEFINITIONS

### G.8.7 Tuck Width

The width of a **tuck** measured at 90° to the **tuck** centreline.

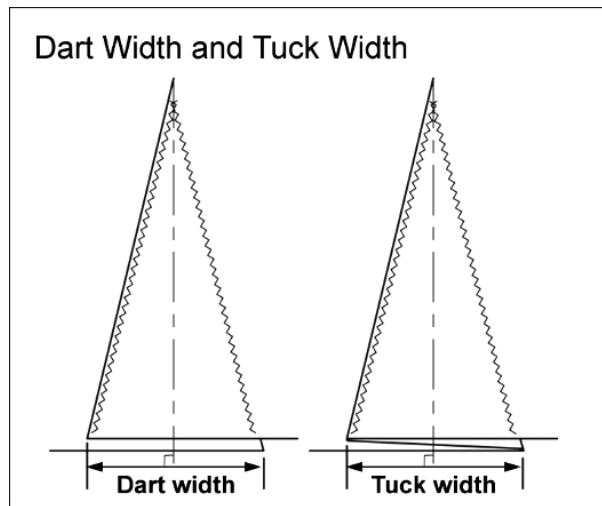

### G.8.8 Attachment Size

#### (a) AT A CORNER OR AN EDGE

##### (i) LENGTH

**AT THE HEAD:** The dimension from the **head point** along the **luff** or its extension to a line through the highest point of the **attachment** at 90° to the **luff**.

**AT THE TACK:** The dimension from the **tack point** along the **luff** or its extension to a line through the lowest point of the **attachment** at 90° to the **luff**.

**AT THE CLEW:** The greatest dimension from the **clew point**.

**AT AN EDGE:** The greatest dimension from the **sail edge**.

##### (ii) WIDTH

The greatest dimension measured perpendicular to the length.

#### (b) ELSEWHERE

The greatest dimension of the **attachment**.

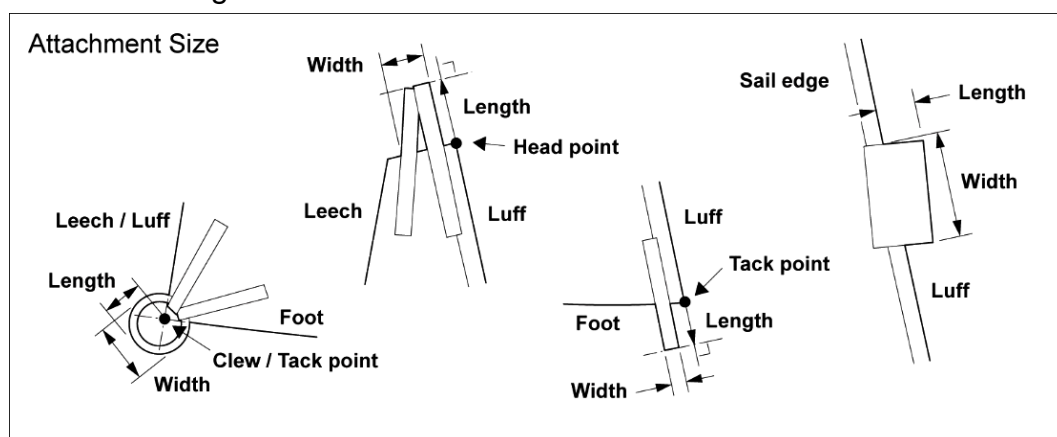

### G.8.9 Window Ply Area

The area of the **window ply**.

## PART 2 DEFINITIONS

---

### G.8.10 Window Area

The **window ply area** excluding seams.

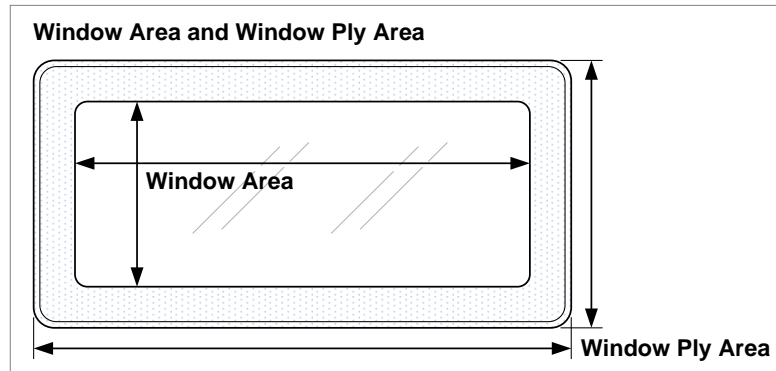

## Subsection B – Additions for Other Sails

The following definitions for non-trilateral sails are additional to or vary those given in Subsection A of this Section. Sails are to be considered as Quadrilateral only when they are set on a gaff, sprit or yard.

### G.2 SAIL EDGES

#### G.2.5 Head

The top edge.

### G.3 SAIL CORNERS

#### G.3.4 Peak

The region where the **head** and the **leech** meet.

#### G.3.5 Throat

The region where the **head** and the **luff** meet.

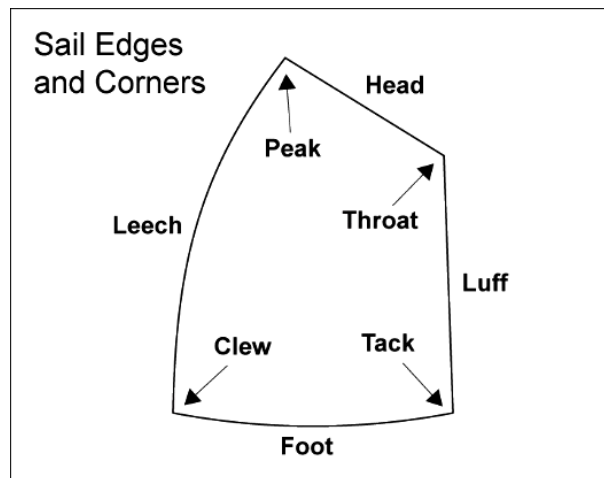

### G.4 SAIL CORNER MEASUREMENT POINTS \*

#### G.4.4 Peak Point

The intersection of the **head** and **leech**, each extended as necessary to bridge a cut-out or a rounded corner.

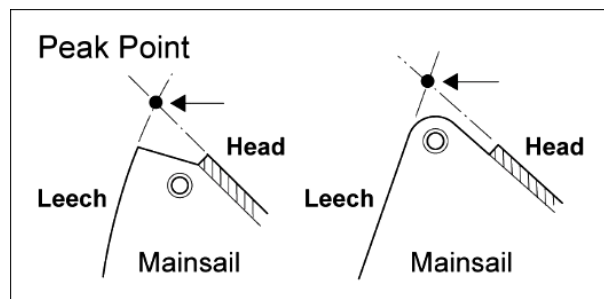

#### G.4.5 Throat Point

The intersection of the **head** and **luff**, each extended as necessary to bridge a cut-out or a rounded corner.

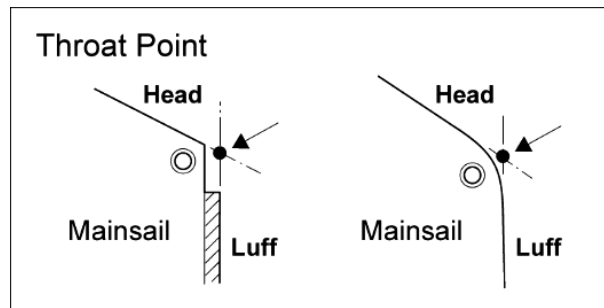

### G.5 OTHER SAIL MEASUREMENT POINTS

#### G.5.2 Half Leech Point

The point on the **leech** equidistant from the **peak point** and the **clew point**.

#### G.5.3 Three-Quarter Leech Point

The point on the **leech** equidistant from the **peak point** and the **half leech point**.

#### G.5.4 Seven-Eighths Leech Point

The point on the **leech** equidistant from the **peak point** and the **three-quarter leech point**.

#### G.5.5 Upper Leech Point

The point on the **leech** a specified distance from the **peak point**.

#### G.5.8 Half Luff Point

The point on the **luff** equidistant from the **peak point** and the **tack point**.

#### G.5.9 Three-Quarter Luff Point

The point on the **luff** equidistant from the **peak point** and the **half luff point**.

#### G.5.10 Seven-Eighths Luff Point

The point on the **luff** equidistant from the **peak point** and the **three-quarter luff point**.

### G.7 PRIMARY SAIL DIMENSIONS

See H.5.

#### G.7.2 Leech Length

The distance between the **peak point** and the **clew point**.

#### G.7.3 Luff Length

The distance between the **throat point** and the **tack point**.

#### G.7.10 Diagonals

##### (a) CLEW DIAGONAL

The distance between the **clew point** and the **throat point**.

##### (b) TACK DIAGONAL

## PART 2 DEFINITIONS

---

The distance between the **tack point** and the **peak point**.

### G.7.11 Foot Median

The distance between the **peak point** and the **mid foot point**.

### G.7.13 Head Length

The distance between the **peak point** and the **throat point**.

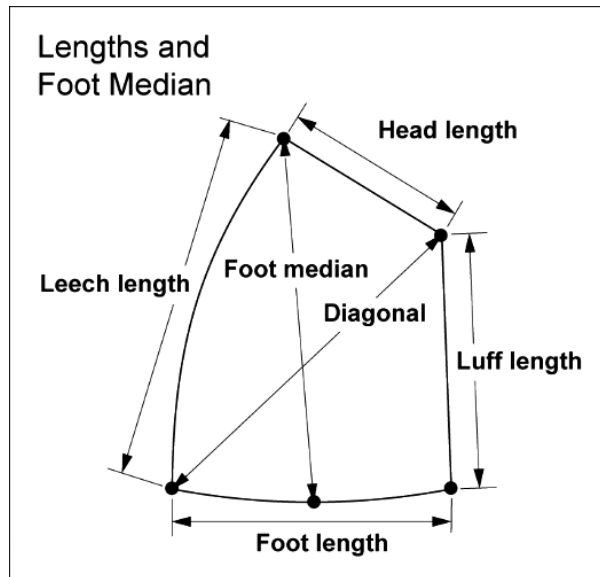

# PART 3 – RULES GOVERNING EQUIPMENT CONTROL AND INSPECTION

---

## Section H – Equipment Control and Inspection

### H.1 CERTIFICATION CONTROL

- H.1.1 **Certification measurers** shall not carry out **certification control** of any part of a **boat** owned, designed or built by themselves, or in which they are an interested party, or have a vested interest.
- H.1.2 If a **certification measurer** is in any doubt as to the application of, or compliance with, the **class rules** the question shall be referred to the **certification authority** before signing a **certification control** form or applying a **certification mark**.
- H.1.3 **Certification measurers** carry out **certification control** in another country only if they are appointed or recognised as such by the MNA for that country.

### H.2 EQUIPMENT INSPECTION

- H.2.1 If an **equipment inspector** is in any doubt as to the application of, or compliance with, the **class rules**, the question should be referred to the **class rules authority**.

### H.3 MEASUREMENT AXES

- H.3.1 For a **boat**, unless otherwise specified, words such as “fore”, “aft”, “above”, “below”, “height”, “depth”, “length”, “beam”, “freeboard”, “inboard” and “outboard” shall be taken to refer to the **boat** in **measurement trim**. All measurements denoted by these, or similar words, shall be taken parallel to one of the three **major axes**.
- H.3.2 For a component, unless otherwise specified, width, thickness, length etc. shall be measured as appropriate for that component, if relevant without reference to the **major axes**.
- H.3.3 Unless otherwise specified, a measurement shall be the shortest distance between the respective measurement points.
- H.3.4 Unless otherwise specified, longitudinal measurements shall be taken parallel to the longitudinal **major axis**.

## H.4 RIG MEASUREMENT

H.4.1 Measurements in the length direction shall be taken along the **spar** at the side relevant for the measurement and between sectional planes through the measurement points at 90° to the **spar** at each point.

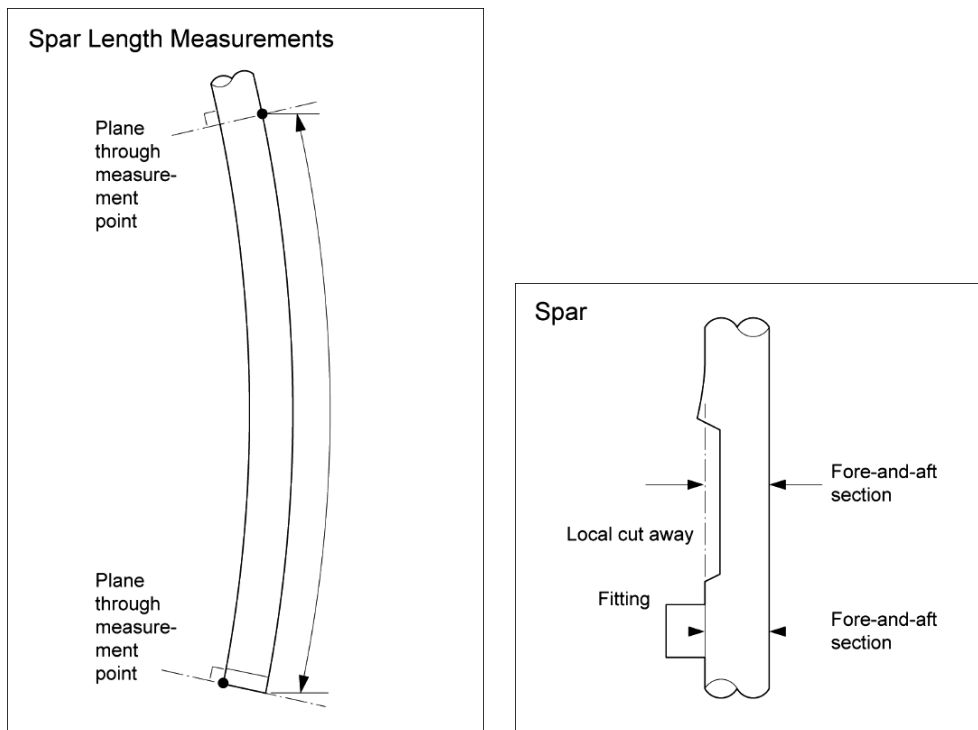

H.4.2 **Fittings**, local curvature and local cut away, shall be ignored when measuring a **spar** or dimensions taken to a **spar**.

H.4.3 No external pressure shall be applied to a **spar** when measuring unless specifically prescribed.

H.4.4 Adjustable **fittings** shall be set in the position that gives the greatest value when the measurement is taken.

H.4.5 **Mast spar deflection** and **boom spar deflection** shall be checked with free ends of **rigging** not supported by the **spar**.

H.4.6 **Mast tip weight** shall be checked with any **halyards** fully hoisted and with tails on the **lower limit mark** and **rigging** pulled taut and tied to the **spar** at the **lower limit mark**.

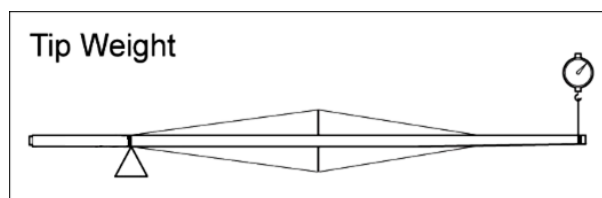

H.4.7 **Mast centre of gravity height** shall be checked with any **halyards** fully hoisted and with tails on the **lower limit mark** and **rigging** pulled taut and tied to the **spar** as close to the **lower limit point** as possible.

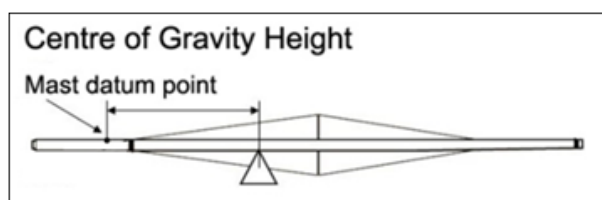



## H.5 SAIL MEASUREMENT

### H.5.1 Condition of the Sail

For measurement the **sail** shall:

- (a) be dry,
- (b) not be attached to **spars** or **rigging**,
- (c) unless the **class rules** prescribe otherwise, have all battens removed,
- (d) have pockets of any type flattened out,
- (e) have just sufficient tension applied to remove wrinkles across the line of the measurement being taken,
- (f) have only one measurement taken at a time and
- (g) be weighed with all **attachments**.

### H.5.2 Hollows in Sail Leeches

Where there is a **sail leech hollow** and a measurement point falls in the hollow:

between adjacent **batten pockets**

between the **aft head point** and adjacent **batten pocket**

between the **clew point** and adjacent **batten pocket**

at an **attachment**.

the **sail** shall be flattened out in the area of the **sail edge**, the **sail edge hollow** shall be bridged by a straight line and the shortest distance from the measurement point to the straight line shall be measured. This distance shall be added to the measurement being taken.

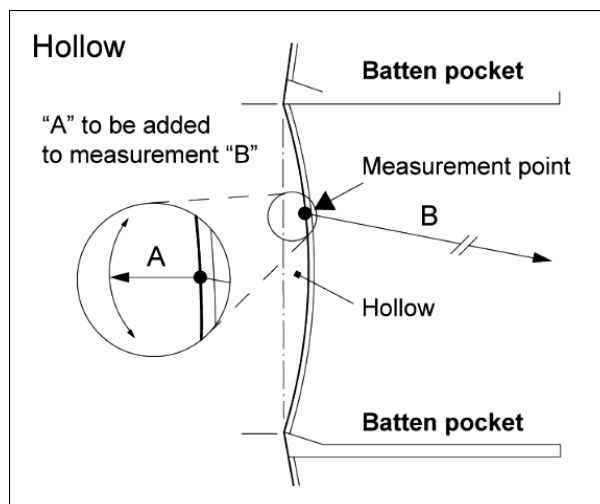

### H.5.3 Excluding Attachments

**Attachments** at a **sail edge**, other than a bolt rope and **tabling**, shall be excluded when measuring.

### H.5.4 Extended as necessary

When there is a cut-out or rounded corner in the **sail edges** at the **clew**, **tack**, **peak**, **throat**, **spinnaker head** or an **aft head point**, the **corner point** shall be found by extending the sail edges as necessary to bridge the cut-out or rounded corner.

- (a) A uniform thickness batten may be used for that purpose, placed along each **sail edge** and bent in a way to match the curve of the **sail edge** up to the start of the cut-out or the rounded corner.
- (b) When the cut-out is not clearly defined and a repeatable corner point cannot be found, ERS H.1.2 shall apply. The **certification control** may be suspended until the sail cut-out is made clear to the satisfaction of the **certification measurer**.
- (c) Batten specifications may be prescribed in **class rules**.
- (d) **Class Rules** may vary ERS H.5.4

#### H.5.5 Spinnaker Half Girth Measurement

The **spinnaker** shall be folded along its centreline with the **luff** on top of the **leech**.

### H.6 CHECKING MATERIALS

Materials are subject to **certification control** only if specifically prescribed by the **Class Rules**.

### H.7 BOAT MEASUREMENT

#### H.7.1 Conditions for Weight and Flotation Measurement

The **boat** shall:

be dry.

be in compliance with the **class rules**.

Unless otherwise specified in the *rules*, any of the following shall be included:

**rig** including **spinnaker pole(s)**, **whisker poles** and/or **jockey pole**

**main sheet** and **mizzen sheet**,

**vang**,

inboard engine or outboard engine in stowed position,

fitted berth cushions on board in their normal positions,

all permanent fixtures and **fittings** and items of accommodation.

Unless otherwise specified in the *rules*, any of the following shall be excluded:

**sails**

fuel, water, **variable ballast** or the content of any other tanks,

gas bottles

portable safety equipment

and all other unfitted or loose equipment.

# APPENDIX 1

---

The following rules in The RRS govern equipment, the use of equipment and changes to and compliance with **class rules**:

- 1 Safety
- 6.1 World Sailing Regulations
- 40 Personal Flotation Devices
- 42 Propulsion
- 45 Hauling Out; Making Fast; Anchoring
- 47 Trash Disposal
- 48 Limitations on Equipment and Crew
- 49 Crew Position; Lifelines
- 50 Competitor Clothing and Equipment
- 51 Movable Ballast
- 52 Manual Power
- 53 Skin Friction
- 54 Forestays and Headsail Tacks
- 55 Setting and Sheeting Sails
- 56 Fog Signals and Lights; Traffic Separation Schemes
- 60.5(d) Decisions on Protests Concerning Class Rules
- 77 Identification on Sails
- 78 Compliance with Class Rules; Certificates
- 87 Changes to Class Rules

Appendix G – Identifications on Sails

Appendix H – Weighing Clothing and Equipment

Note that racing rule 86.1 permits some of these racing rules to be changed by prescriptions of a national authority, notice of race or sailing instructions or **class rules**.

Appendices G and H of the RRS and the World Sailing Advertising Code are made applicable by racing rules 77, 50 and 6.1 respectively. That code and those appendices contain rules governing equipment. Certain rules in the International Regulations for Preventing Collisions at Sea (IRPCAS) or applicable government rules are made applicable by racing rule 56, and certain specifications in the World Sailing Offshore Special Regulations are made applicable by racing rule 49.

## APPENDIX 2

---

Abbreviations for primary sail dimensions:

|                               | <b>ERS Rule Reference</b> | <b>Dimension</b>             | <b>Abbreviation</b> |
|-------------------------------|---------------------------|------------------------------|---------------------|
| <b>Mainsail</b>               | G.7.4 (a)                 | Mainsail Quarter Width       | MQW                 |
|                               | G.7.5 (a)                 | Mainsail Half Width          | MHW                 |
|                               | G.7.6 (a)                 | Mainsail Three-Quarter Width | MTW                 |
|                               | G.7.8 (a)                 | Mainsail Upper Width         | MUW                 |
|                               | G.7.9 (a)                 | Mainsail Top Width           | MHB                 |
| <b>Headsail</b>               | G.7.3                     | Headsail Luff Length         | HLU                 |
|                               | G.7.4 (a)                 | Headsail Quarter Width       | HQW                 |
|                               | G.7.5 (a)                 | Headsail Half Width          | HHW                 |
|                               | G.7.6 (a)                 | Headsail Three-Quarter Width | HTW                 |
|                               | G.7.8 (a)                 | Headsail Upper Width         | HUW                 |
|                               | G.7.9 (a)                 | Headsail Top Width           | HHB                 |
|                               | G.7.12                    | Headsail Luff Perpendicular  | HLP                 |
| <b>Spinnaker</b>              | G.7.3                     | Spinnaker Luff Length        | SLU                 |
|                               | G.7.2                     | Spinnaker Leech Length       | SLE                 |
|                               | G.7.1                     | Spinnaker Foot Length        | SFL                 |
|                               | G.7.5 (b)                 | Spinnaker Half Width         | SHW                 |
| <b>Quadrilateral Mainsail</b> | G.7.2                     | Leech Length                 | QLE                 |
|                               | G.7.13                    | Head Length                  | QHL                 |
|                               | G.7.1                     | Foot Length                  | QFL                 |
|                               | G.7.10 (a)                | Clew Diagonal                | QCD                 |

# INDEX OF DEFINITIONS

| Defined Term                   | Rule           | Defined Term              | Rule            |
|--------------------------------|----------------|---------------------------|-----------------|
| <b>A</b>                       |                | Bowsprit Weight           | F.5.3 (c)       |
| Aft Head Point                 | G.5.6          | Bulb                      | E.1.2 (e)       |
| Age Date                       | C.6.5 (b)      | Bumkin                    | F.1.4 (c) (ii)  |
| Attachment Size                | G.8.8          | <b>C</b>                  |                 |
| Attachments                    | G.1.4 (o)      | Canting Keel              | E.1.2 (c)       |
| <b>B</b>                       |                | Centreboard               | E.1.2 (g)       |
| Back Lines                     | F.1.7 (b) (x)  | Certificate               | C.3.3           |
| Backstay                       | F.1.7 (b) (ii) | Certification             | C.3.2           |
| Backstay Height                | F.2.3 (h)      | Certification Authority   | C.3.1           |
| Ballast                        | C.6.3 (f)      | Certification Control     | C.4.2           |
| Bar                            | F.1.4 (d) (vi) | Certification Mark        | C.3.4           |
| Batten Pocket                  | G.1.4 (k)      | Certification<br>Measurer | C.4.4           |
| Batten Pocket Length           | G.8.1          | Certify                   | C.3.2           |
| Batten Pocket Patch            | G.6.4          | Chafing Patch             | G.6.5           |
| Batten Pocket Width            | G.8.2          | Checkstay                 | F.1.7 (b) (iv)  |
| Bilge Keel                     | E.1.2 (b)      | Checkstay Height          | F.2.3 (i)       |
| Bilgeboard                     | E.1.2 (i)      | Class Authority           | C.1.1           |
| Boat                           | C.6.1          | Class Rules               | C.2.1           |
| Boat Beam                      | C.6.4 (b)      | Class Rules Authority     | C.2.4           |
| Boat Length                    | C.6.4 (a)      | Cleaning                  | C.7.1 (g)       |
| Boat Weight                    | C.6.4 (h)      | Clew                      | G.3.1           |
| Body of the Sail               | G.1.4 (a)      | Clew Diagonal             | G.7.10 (a)      |
| Bonding                        | C.7.1 (d)      | Clew Point                | G.4.1           |
| Boom                           | F.1.4 (b)      | Closed Class Rules        | C.2.2           |
| Boom Spar Cross<br>Section     | F.3.3 (d)      | Coating                   | C.7.1 (e)       |
| Boom Spar<br>Curvature         | F.3.3 (b)      | Connect                   | C.6.3 (g)       |
| Boom Spar<br>Deflection        | F.3.3 (c)      | Corrector Weight          | C.6.3 (f) (v)   |
| Boom Weight                    | F.3.3 (e)      | Crew                      | C.5.1           |
| Bowsprit                       | F.1.4 (c) (i)  | Crew Harness              | C.5.5           |
| Bowsprit Inner Limit<br>Mark   | F.5.2 (a)      | Cutter Rig                | F.1.2 (c)       |
| Bowsprit Inner Point           | F.5.1 (a)      | <b>D</b>                  |                 |
| Bowsprit Outer Limit<br>Mark   | F.5.2 (b)      | Daggerboard               | E.1.2 (h)       |
| Bowsprit Outer Point           | F.5.1 (b)      | Dart                      | G.1.4 (i)       |
| Bowsprit Point<br>Distance     | F.5.3 (a)      | Dart Width                | G.8.6           |
| Bowsprit Spar Cross<br>Section | F.5.3 (b)      | Deck Spreader             | F.1.4 (c) (iii) |
|                                |                | Double Luff Sail          | G.1.4 (g)       |
|                                |                | Draft                     | C.6.4 (e)       |
|                                |                | <b>E</b>                  |                 |
|                                |                | Equipment Inspector       | C.4.6           |
|                                |                | Equipment<br>Regulations  | C.4.9           |

## INDEX OF DEFINITIONS

| Defined Term               | Rule             | Defined Term                    | Rule            |
|----------------------------|------------------|---------------------------------|-----------------|
| Event Equipment Inspection | C.4.3            | Headsail Hoist Height           | F.2.3 (k)       |
| Event Limitation Mark      | C.4.8            | Heel Point                      | F.2.2 (b)       |
| External Ballast           | C.6.3 (f) (ii)   | Helmsperson                     | C.5.2           |
| <b>F</b>                   |                  | Hull                            | D.1.1           |
| Fairing                    | C.7.1 (i)        | Hull Appendage                  | E.1.1           |
| Fastening                  | C.7.1 (c)        | Hull Appendage Assembly Weight  | E.2.2           |
| Fin                        | E.1.2 (d)        | Hull Appendage Depth            | C.6.4 (j)       |
| Fitting                    | C.7.1 (b)        | Hull Appendage Weight           | E.2.1           |
| Flotation Trim             | C.6.3 (c)        | Hull Beam                       | D.3.2           |
| Flutter Patch              | G.6.6            | Hull Datum Point                | D.2.1           |
| Flying Lines               | F.1.7 (b) (viii) | Hull Depth                      | D.3.3           |
| Foot                       | G.2.1            | Hull Length                     | D.3.1           |
| Foot Irregularity          | G.8.3            | Hull Spars                      | F.1.4 (c)       |
| Foot Length                | G.7.1            | Hull Weight                     | D.4.1           |
| Foot Median                | G.7.11           | Hydrofoil                       | E.1.2 (m)       |
| Foremast                   | F.1.4 (a) (ii)   | <b>I</b>                        |                 |
| Foremast Sail              | G.1.3 (b)        | Impact Vest                     | C.5.6           |
| Foremast Sail Boom         | F.1.4 (b) (i)    | In-House Certification Measurer | C.4.5           |
| Forestay                   | F.1.7 (a) (iii)  | Installation                    | C.7.1 (a)       |
| Forestay Height            | F.2.3 (f)        | Internal Ballast                | C.6.3 (f) (i)   |
| Foretriangle               | F.1.8            | <b>J</b>                        |                 |
| Foretriangle Area          | F.6.1 (c)        | Jockey Pole                     | F.1.4 (d) (vii) |
| Foretriangle Base          | F.6.1 (a)        | <b>K</b>                        |                 |
| Foretriangle Height        | F.6.1 (b)        | Keel                            | E.1.2 (a)       |
| Front Lines                | F.1.7 (b) (ix)   | Ketch Rig                       | F.1.2 (d)       |
| Fundamental Measurement    | C.4.1            | Kite                            | G.1.3 (e)       |
| <b>G</b>                   |                  | Kite-Board                      | C.6.2 (d)       |
| Gaff                       | F.1.4 (d) (iii)  | <b>L</b>                        |                 |
| <b>H</b>                   |                  | Laminated Ply                   | G.1.4 (e)       |
| Half Leech Point           | G.5.2            | Leech                           | G.2.2           |
| Half Luff Point            | G.5.8            | Leech Length                    | G.7.2           |
| Half Width                 | G.7.5            | Licensed Manufacturer's Mark    | C.3.5           |
| Halyard                    | F.1.7 (b) (i)    | Limit Mark                      | C.4.7           |
| Head                       | G.3.2            | Limit Marks Width               | F.1.9           |
| Head (Other Sails)         | G.2.5            | List Angle                      | C.6.4 (i)       |
| Head Length                | G.7.13           | Lower Limit Mark                | F.2.1 (a)       |
| Head Point                 | G.4.2            | Lower Point                     | F.2.2 (d)       |
| Headsail                   | G.1.3 (d)        |                                 |                 |
| Headsail Boom              | F.1.4 (b) (ii)   |                                 |                 |

## INDEX OF DEFINITIONS

| <b>Defined Term</b>           | <b>Rule</b>     | <b>P</b>                  |                 |
|-------------------------------|-----------------|---------------------------|-----------------|
| Lower Point Height            | F.2.3 (b)       | Peak                      | G.3.4           |
| Lubricating                   | C.7.1 (j)       | Peak Point                | G.4.4           |
| Luff                          | G.2.3           | Personal Equipment        | C.5.3           |
| Luff Length                   | G.7.3           | Personal Flotation Device | C.5.4           |
| Luff Perpendicular            | G.7.12          | Ply                       | G.1.4 (b)       |
| <b>M</b>                      |                 | Polishing                 | C.7.1 (h)       |
| Main Boom                     | F.1.4 (b) (iii) | Portable Equipment        | C.6.6           |
| Mainmast                      | F.1.4 (a) (i)   | Primary Reinforcement     | G.6.1           |
| Mainsail                      | G.1.3 (a)       | <b>Q</b>                  |                 |
| Mainsail Luff Mast Distance   | F.2.3 (d)       | Quarter Leech Point       | G.5.1           |
| Maintenance                   | C.7.3           | Quarter Luff Point        | G.5.7           |
| Major Axes                    | C.6.3 (a)       | Quarter Width             | G.7.4           |
| Mast                          | F.1.4 (a)       | <b>R</b>                  |                 |
| Mast Centre of Gravity Height | F.2.3 (r)       | Reinforcement Size        | G.8.4           |
| Mast Datum Point              | F.2.2 (a)       | Repair                    | C.7.4           |
| Mast Length                   | F.2.3 (a)       | Rig                       | F.1.1           |
| Mast Spar Cross Section       | F.2.3 (o)       | Rigging                   | F.1.6           |
| Mast Spar Curvature           | F.2.3 (m)       | Rigging Point             | F.2.3 (e)       |
| Mast Spar Deflection          | F.2.3 (n)       | Rudder                    | E.1.2 (j)       |
| Mast Tip Weight               | F.2.3 (q)       | Running Backstay          | F.1.7 (b) (iii) |
| Mast Weight                   | F.2.3 (p)       | Running Rigging           | F.1.7 (b)       |
| Maximum Draft                 | C.6.4 (g)       | <b>S</b>                  |                 |
| Measurement Trim              | C.6.3 (b)       | Sail                      | G.1.1           |
| Mid Foot Point                | G.5.12          | Sail Corner               | G.3             |
| Minimum Draft                 | C.6.4 (f)       | Sail Edge                 | G.2             |
| Mizzen                        | G.1.3 (c)       | Sail Edge Shape           | G.1.4 (p)       |
| Mizzen Boom                   | F.1.4 (b) (iv)  | Sail Leech Hollow         | G.2.4           |
| Mizzenmast                    | F.1.4 (a) (iii) | Sail Opening              | G.1.4 (l)       |
| Modification                  | C.7.2           | Sail Reinforcement        | G.6             |
| Monohull                      | C.6.2 (a)       | Sanding                   | C.7.1 (f)       |
| Moveable Ballast              | C.6.3 (f) (iii) | Schooner Rig              | F.1.2 (f)       |
| Multihull                     | C.6.2 (b)       | Sealed Closed             | C.7.1 (l)       |
| <b>O</b>                      |                 | Sealed in Position        | C.7.1 (k)       |
| Open Class Rules              | C.2.3           | Seam                      | G.1.4 (h)       |
| Outer Limit Mark              | F.3.2 (a)       | Seam Width                | G.8.5           |
| Outer Point                   | F.3.1 (a)       | Secondary Reinforcement   | G.6.2           |
| Outer Point Distance          | F.3.3 (a)       | Series Date               | C.6.5 (a)       |
| Outhaul                       | F.1.7 (b) (v)   | Set Flying                | G.1.2           |
| Outrigger                     | F.1.4 (c) (iv)  | Seven-Eighths Leech Point | G.5.4           |

## INDEX OF DEFINITIONS

---

| Defined Term              | Rule            | Term                | Rule           |
|---------------------------|-----------------|---------------------|----------------|
| Seven-Eighths Luff Point  | G.5.10          | Three-Quarter Width | G.7.6          |
| Seven-Eighths Width       | G.7.7           | Throat              | G.3.5          |
| Sheer                     | D.1.3           | Throat Point        | G.4.5          |
| Sheerline                 | D.1.2           | Top Point           | F.2.2 (c)      |
| Sheet                     | F.1.7 (b) (vi)  | Top Width           | G.7.9          |
| Shroud                    | F.1.7 (a) (i)   | Trapeze             | F.1.7 (c) (i)  |
| Shroud Height             | F.2.3 (g)       | Trapeze Height      | F.2.3 (j)      |
| Single-Ply Sail           | G.1.4 (f)       | Trim Tab            | E.1.2 (k)      |
| Skeg                      | E.1.2 (f)       | Tuck                | G.1.4 (j)      |
| Sloop Rig                 | F.1.2 (b)       | Tuck Width          | G.8.7          |
| Soft Sail                 | G.1.4 (c)       | <b>U</b>            |                |
| Spar                      | F.1.3           | Una Rig             | F.1.2 (a)      |
| Spar Cross Section        | F.4 (b)         | Upper Leech Point   | G.5.5          |
| Spar Length               | F.4 (a)         | Upper Limit Mark    | F.2.1 (b)      |
| Spar Weight               | F.4 (c)         | Upper Luff Point    | G.5.11         |
| Spinnaker                 | G.1.3 (f)       | Upper Point         | F.2.2 (e)      |
| Spinnaker Guy             | F.1.7 (b) (vii) | Upper Point Height  | F.2.3 (c)      |
| Spinnaker Half Girth      | G.7.13          | Upper Width         | G.7.8          |
| Spinnaker Hoist Height    | F.2.3 (l)       | <b>V</b>            |                |
| Spinnaker Pole            | F.1.4 (d) (i)   | Vang                | F.1.7 (b) (xi) |
| Spinnaker Pole Fitting    | F.2.4 (b)       | Variable Ballast    | C.6.3 (f) (iv) |
| Spinnaker Tack Distance   | F.7.1           | <b>W</b>            |                |
| Spreader                  | F.1.5           | Waterline           | C.6.3 (d)      |
| Spreader Length           | F.2.4 (a) (i)   | Waterline Beam      | C.6.4 (d)      |
| Spreader Height           | F.2.4 (a) (ii)  | Waterline Length    | C.6.4 (c)      |
| Sprit                     | F.1.4 (d) (iv)  | Waterplane          | C.6.3 (e)      |
| Standing Rigging          | F.1.7 (a)       | Whisker Pole        | F.1.4 (d) (ii) |
| Stay                      | F.1.7 (a) (ii)  | Window              | G.1.4 (m)      |
| Stiffening                | G.1.4 (n)       | Window Area         | G.8.10         |
| <b>T</b>                  |                 | Window Ply Area     | G.8.9          |
| Tabling                   | G.6.3           | Windsurfer          | C.6.2 (c)      |
| Tabling Width             | G.8.3 (b)       | Wingfoil            | C.6.2 (e)      |
| Tack                      | G.3.3           | Winglet             | E.1.2 (l)      |
| Tack Diagonal             | G.7.10 (b)      | Wingspan            | E.2.3          |
| Tack Point                | G.4.3           | Wishbone boom       | F.1.4 (b) (v)  |
| Three-Quarter Leech Point | G.5.3           | Woven Ply           | G.1.4 (d)      |
| Three-Quarter Luff Point  | G.5.9           | <b>Y</b>            |                |
|                           |                 | Yard                | F.1.4 (d) (v)  |
|                           |                 | Yaw Rig             | F.1.2 (e)      |